

1/2A HALF-LITE STUNTER INSTRUCTIONS

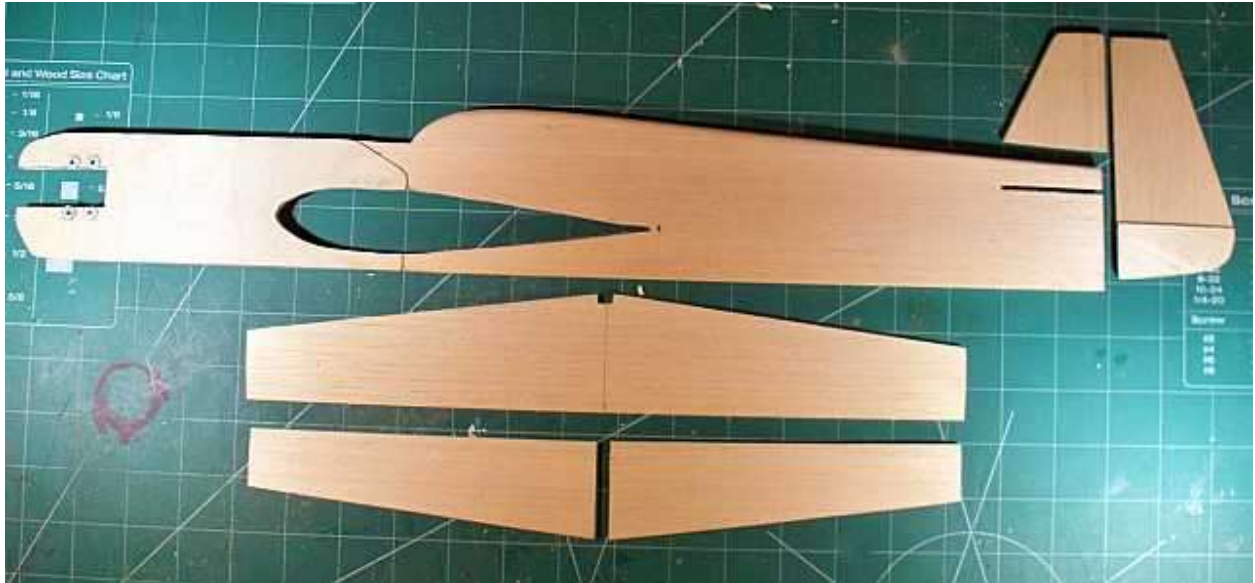

The Wing

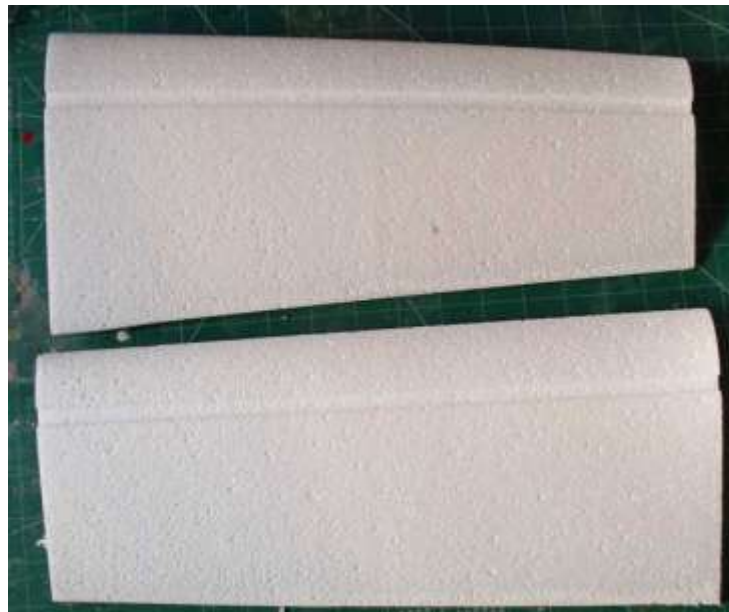

This wing is a Core House Half-Lite combat wing. It is used in 2 AMA published designs. The first one is a Half-Lite Combat model and the second is a C/L carrier model called the Snapper for .15 size engine. I have adapted this wing for an quick easy build 1/2A stunter capable of performing the AMA control line aerobatic pattern. Not only does this model perform the pattern, in the right hands, it is capable of a 500+ score.

The Wing Spar

The spar slot is actually $5/16''$ X $1/8''$, which is hard to find. Instead, I use a $3/8''$ X $1/8''$ spruce or very hard C grain balsa wood for the wing spar. This requires expanding the slot with a razor blade. Use one piece for the top and one for the bottom.

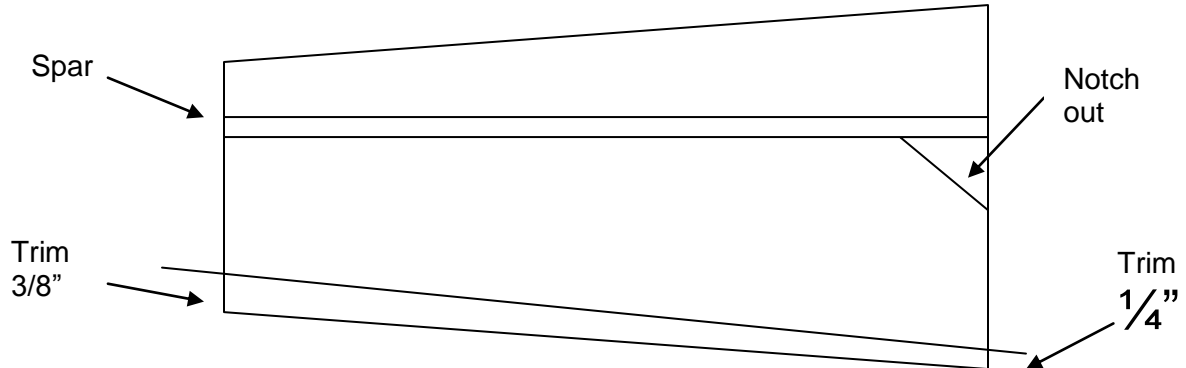

1. Carefully remove the foam wing from the core. The trail edge is very thin, so I cut about $1/4''$ at the root and $3/8$ at the tip off the trailing edge. Use a new razor blade and a long straight edge.



2. Reinforce the trailing edge by running a bead of white glue along $1/4''$ edge of the on both sides and along the edge. Smooth it out with your fingers.



3. Glue the 2 wing halve together using foam safe glue. I prefer Tite Bond or Elmer's Wood Glue.
4. If you need to cut the slot wider for the spar. Use the spar at a guide . Again use foam safe glue. Or you can cut your own spar using a stripper tool. The spar slot is $1/8'' \times 5/16''$.



Option: If you are going to use a balsa spar it need to be reinforced. You wrap the spar slot with a few strains of Dacron line. I used a few strains of carbon tow, since I have a roll on hand.

5. After gluing the spar in the slot, use masking tape to hold it down.

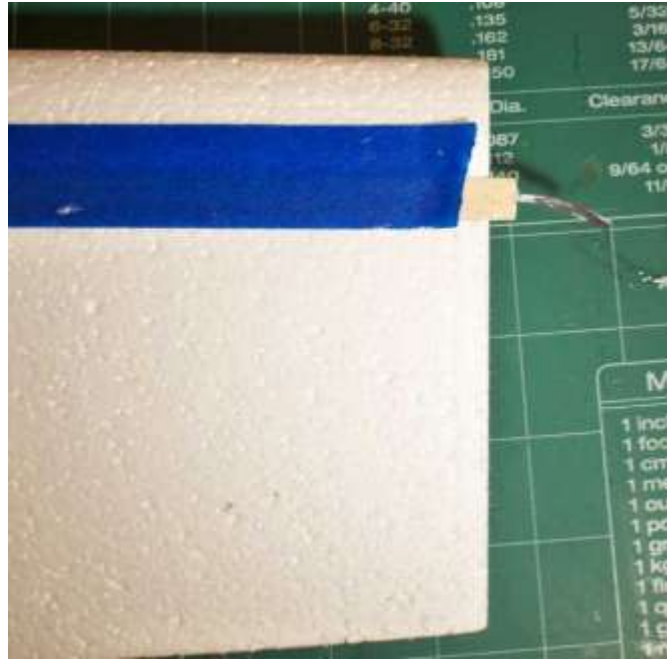

6. Clamp or tape down until is dries.



7. Install the Bell Crank Mount. Glue in a 2-56 blind nut to secure the bellcrank. Use a long razor or box cutter to cut a triangular slot next to the spar on the top the inboard wing.



The fuselage

The design of the fuselage is not important as long you maintain the same nose/tail moment ratio of .60 (5/8.25). The stab is exactly 1" above the center line of the wing. If you do not have my template you can easily create this fuselage. Cut a 20" length section out of a 3" X 1/4" plank of balsa.

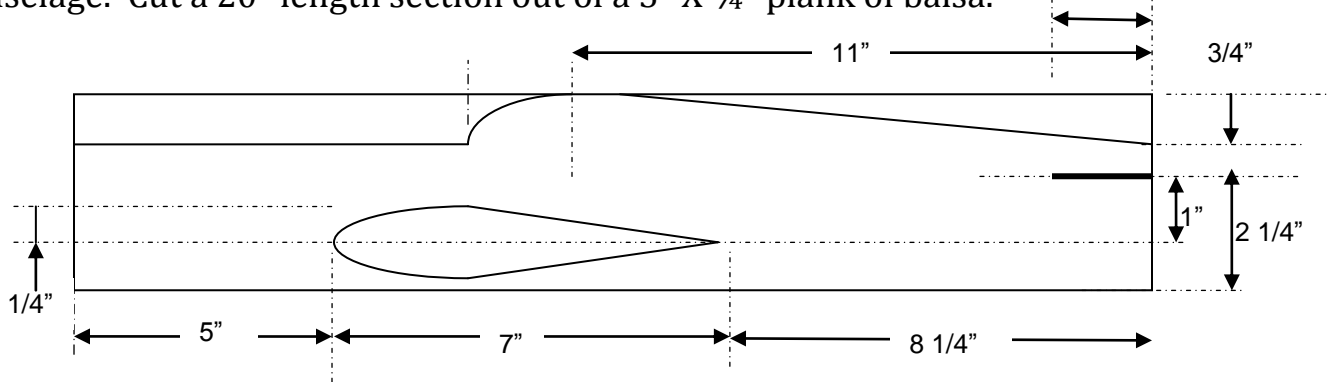

1. Start by drawing a center line length wise 1" above the bottom.
2. Mark of the vertical section for 5" and 7" using a triangle. These represent the nose moment, wing chord and tail moment.
3. Mark the center line for the engine which is 1/4" above the center line.
4. The stab is 1" above the center. Be sure that these lines are perfectly horizontal because this represents the incidence of the model.
5. You can make the canopy anything you wish (turtle-deck, bubble, etc.) because this part of the design has no effect on the models performance.

The Engine Crutch

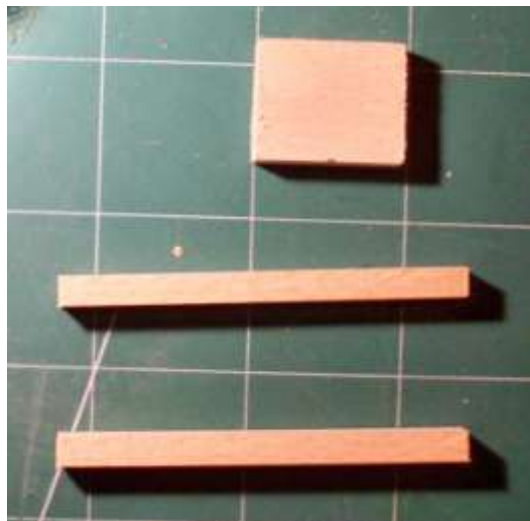

Use to 2 1/4" X 3/16" or 1/4" X 1/4" sticks. Use a piece of 1/4" hard balsa as the spacer. Measure your engine to determine the distance between the mounts.



Tip: For Norvel or Cox Tee Dee the spacing is exactly the diameter of a penny. This width will allow for some play in the engine trust line adjustment.



Always double check the fit before gluing the mounts.

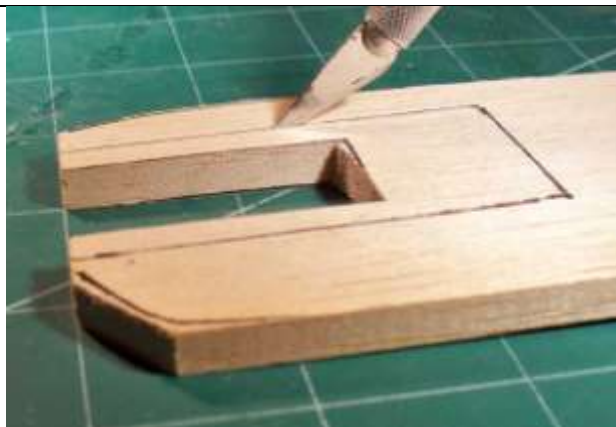

Trace the outline of the engine crutch on the fuselage and carefully cut it out with an Xacto knife or on a scroll saw. Remember to cut along the inside of the line.



Glue the crutch in place.

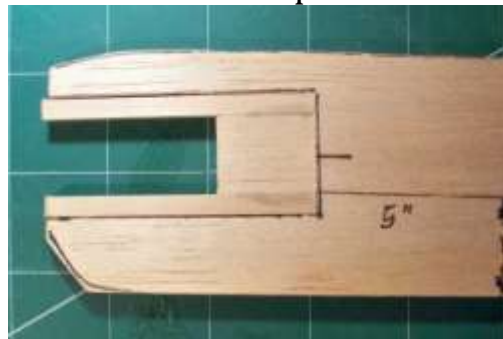

The Engine Mount Doublers

The doublers are cut from 1/32" or 1/16" plywood. The length of the doubler should go back to the spar. Glue the 2 doublers in place after you install the engine crutch.

Optional: If you are installing a landing gear it is a good ideas to install a hardwood mount in that area before gluing the doublers. The magic number

is 10° forward of the C.G. To make it simple, the axle of the wheel should line up close to the leading edge.

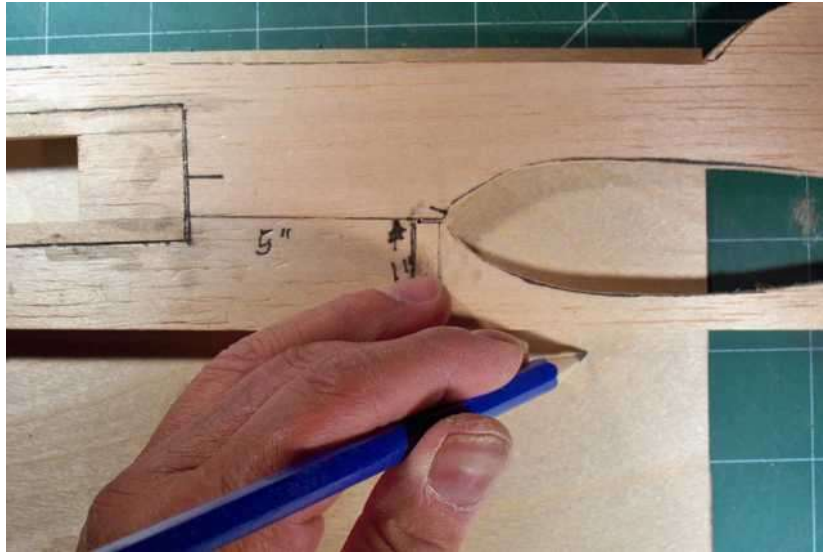

Trace the doubler using the fuselage outline.

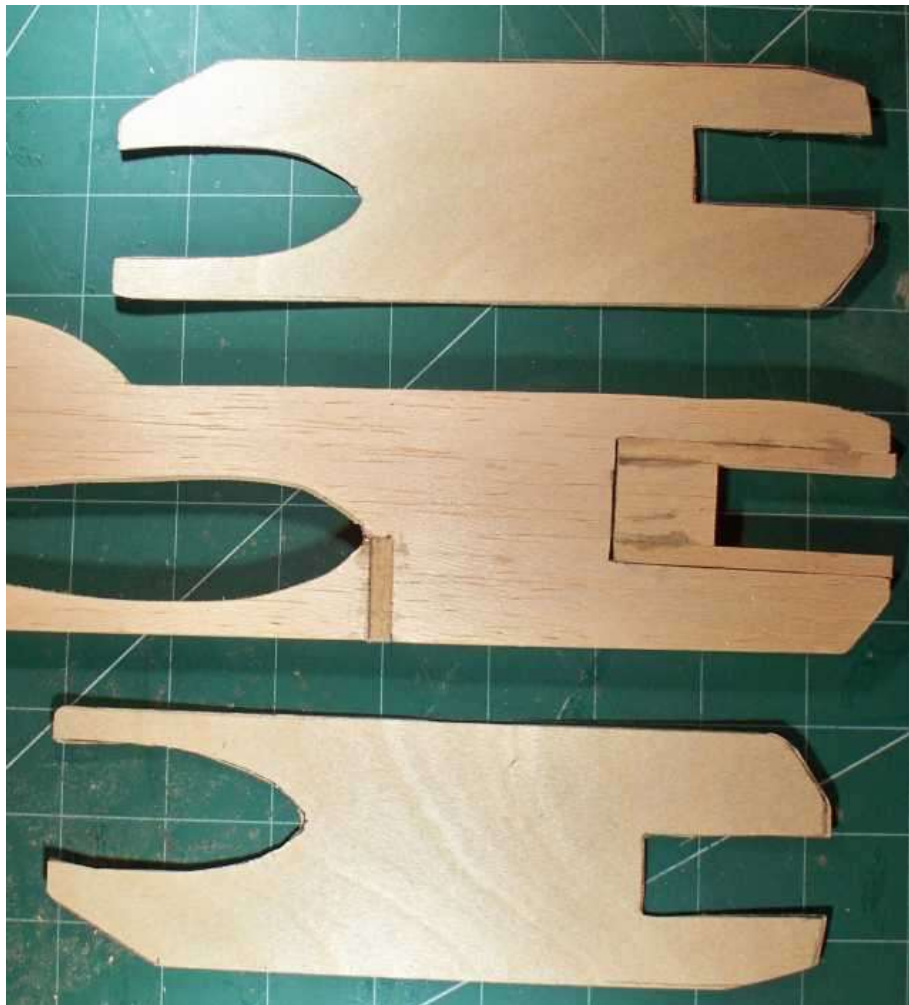

Cut out on the inside line using a scroll saw.

Doubler Assembly.

Glue the 2 plywood doublers with epoxy or polyurethane glue (Gorilla Glue).



Outboard 1/32" Plywood Doubler

Balsa Fuselage

Inboard 1/32" Plywood Doubler

Blind Nuts
3rd balsa doubler
(Optional)



After drilling the hole for the engine, you can install blind nuts behind the inboard plywood doubler. Laminate a 3rd balsa doubler to hide the blind nuts for a cleaner look, This also stiffens the nose of the fuselage.



Clap it down for 24 hours.

Drill the Engine Mount.

At this point you should drill out all the holes you need, like engine, tank and landing gear, before attaching the wing. Glue the blind nuts with CA.

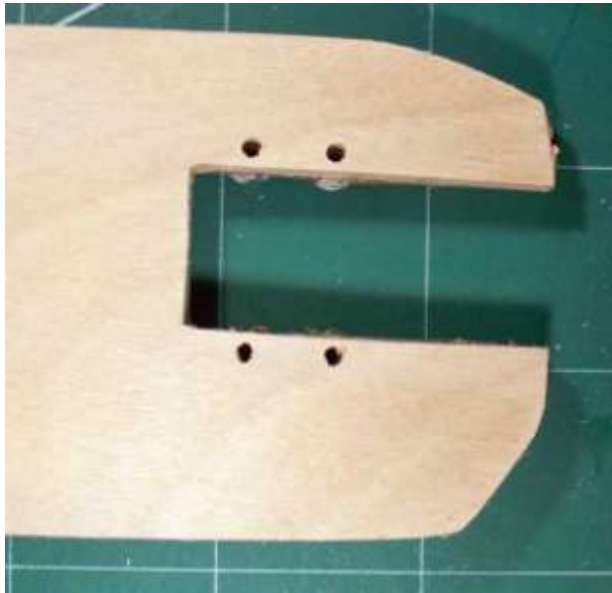

Outboard Side (Engine)

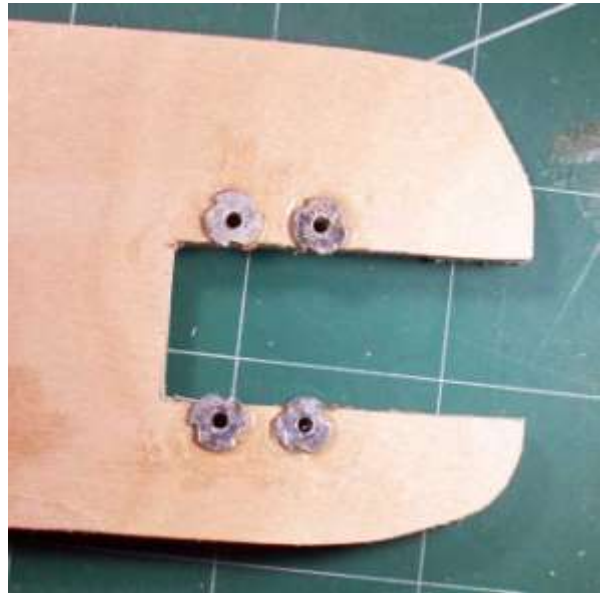

Inboard Side (Blind Nuts)

Balsa Doubler

Glue the 3rd balsa doubler to add stiffness and to cover the blind nut on the inboard side of the fuselage. You might need to hone out the inside to make room for the blind nut. Make it a little oversized so that you can sand it down to blend in with the fuselage.





I like to taper the inboard side of the fuselage toward the rudder to that is blends in.

Tail Wheel

Secure and tail wheel or skid to the back of the fuselage using a hard wood mount. Notch the mount as follows.



Side View

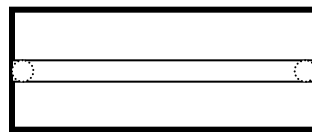

Top View

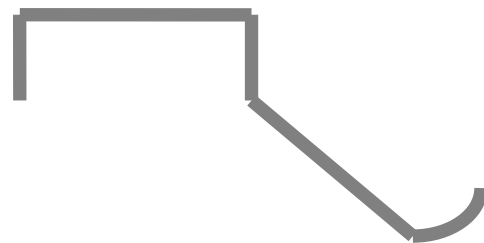

Du-Bro RC Micro Tail Wheel Bracket

Another option is to purchase a tall wheel set for R/C park flyer. The two piece bracket simply glues together to secure pre-bent 1/32 (.032) wire tail wheel strut.



Landing Gear

Landing gear is optional, but if you are going to fly this model in a stunt competition, a landing gear is required in order to receive points for take off. To keep this model light as possible a wire gear using .47 music wire is the best. You can install a 2 wheel gear or a single gear attach to the fuselage. I like to use a single gear at the fuselage and another gear at the wing tip. This will save the most weight because the wing tip gear can double as counter weight.

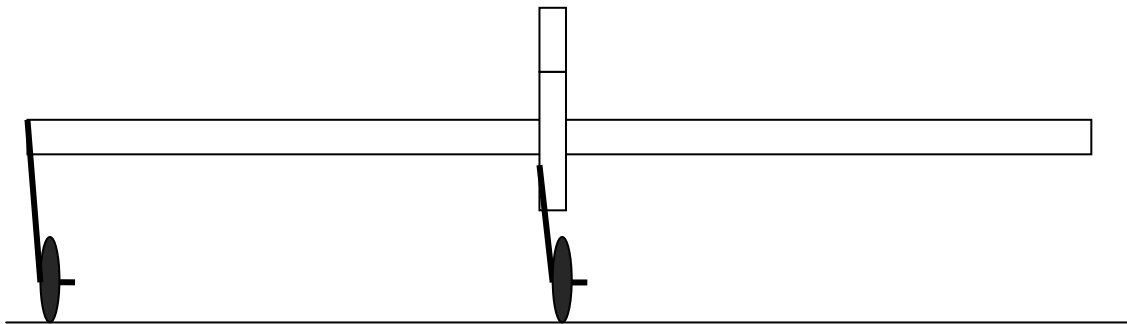

If you are flying off grass, make the outboard gear $\frac{1}{2}$ " shorter or eliminate it all together.

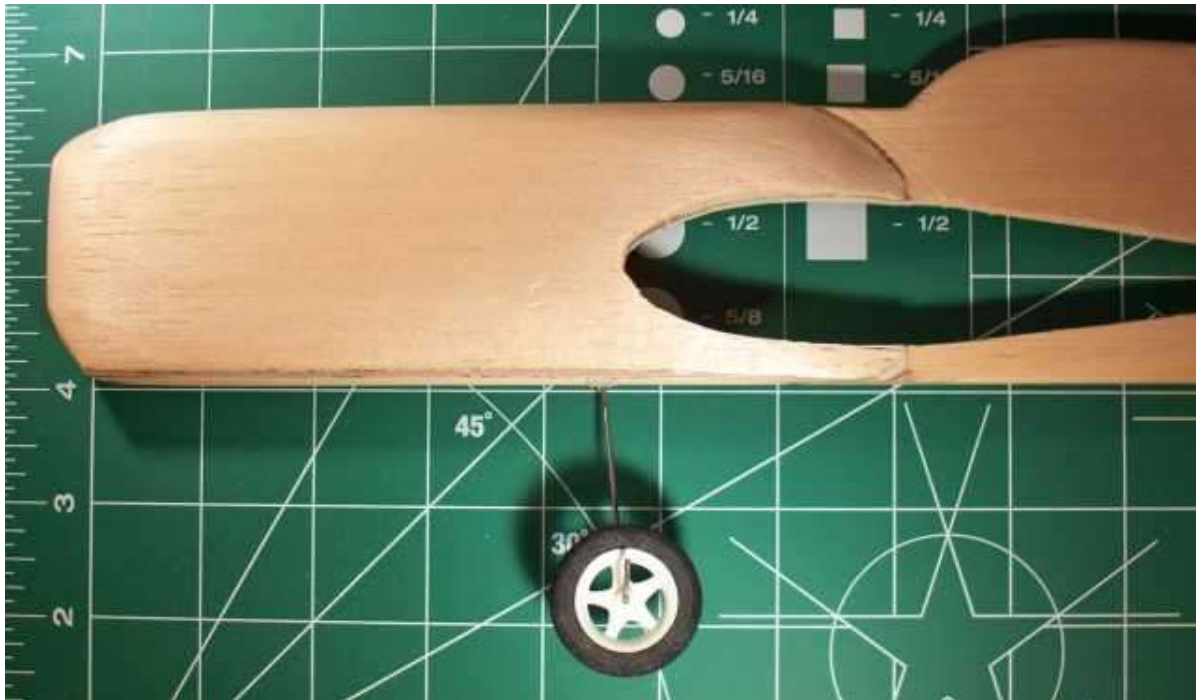

Mount the gear so that the hub of the wheel lines up with the leading edge.

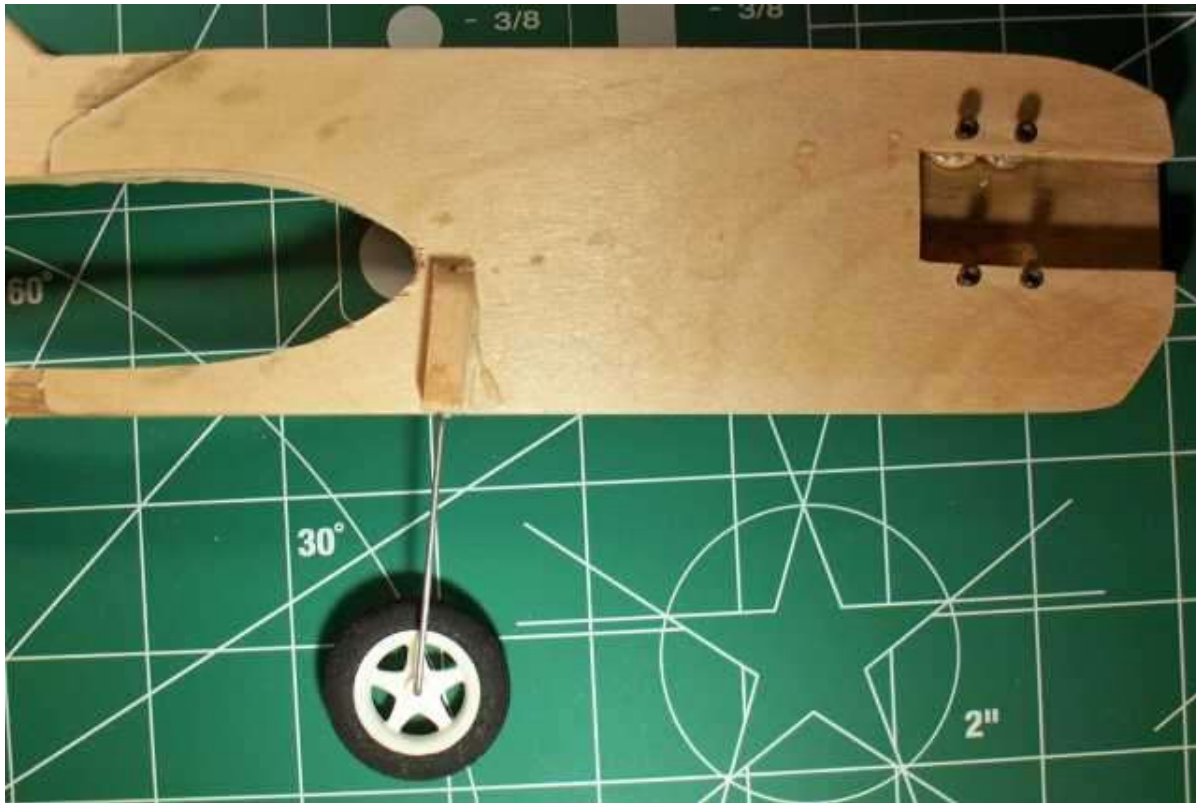

I like to mount the gear a little more forward than you would on a full size stunter because small model have a tendency to flip over, especially when flying off the grass.

Two Wheel Wire Gear

If you are going to install a traditional two wheel wire gear, it should be installed before you glue the 2 plywood doublers. Use a hard wood block similar to the engine mount. This method will result in a cleaner look.

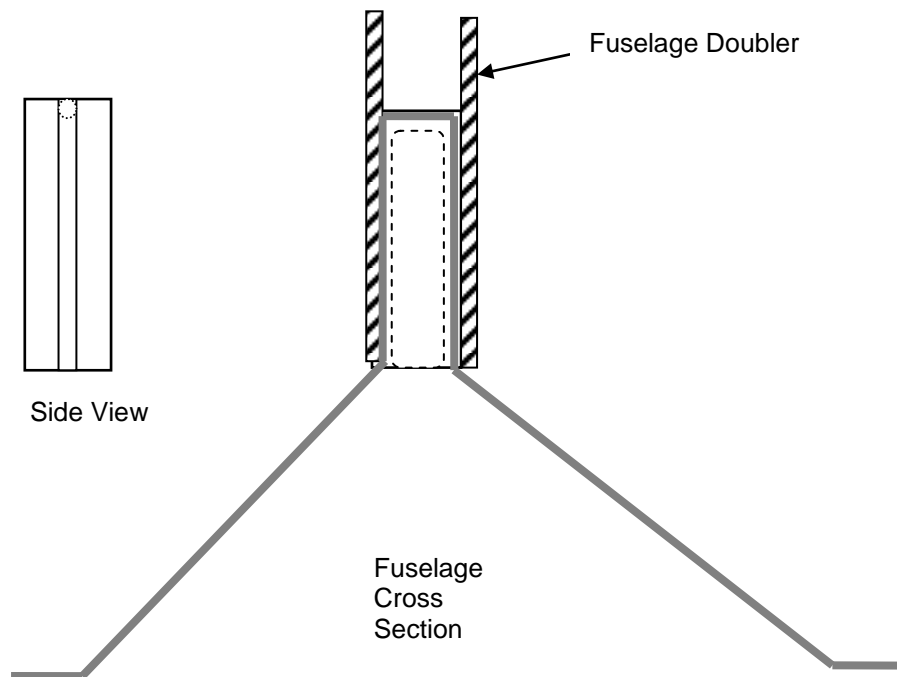

Carbon Gear

Another option is to use a commercial carbon gear designed for light weight 3D R/C models. This type of gear will cost around \$20-\$30. The carbon gear shown below are for a 1/2a proto speed model.



However the weight of this type of gear is only about $\frac{1}{4}$ oz or less.

Insert a piece of ¼" square hardwood in the section where the gear is to be mounted.

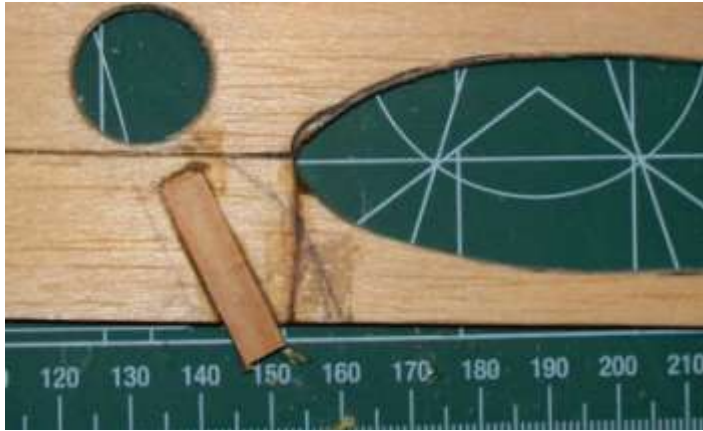

Wheels

Use light weight foam wheels for micro R/C model. I use the 1.25" diameter size.



The Rudder



Cut 2 1/32" doublers for the rudder with the grain lengthwise. If you does not like this shape, you can use your own design.

Use the outside edge for the part that is going to be glued together.



The Stab and Elevator

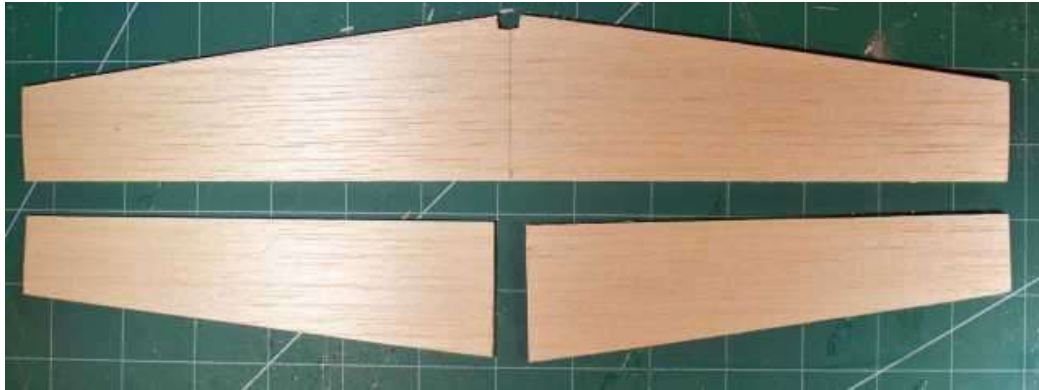

The stabilizer and elevator for this model is design to be cut out easily without the need for a template. The dimensions are simple with no complicated curves. All that is required is and right-angle ruler and a straight edge.

The Elevator Joiner



You to the connect the two elevator half together using one of these methods.

Method 1 -Steel Wire

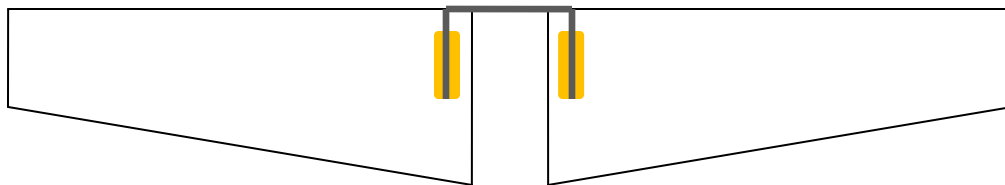

Epoxy a U-shape steel wire to the bottom. This can be reinforced with nylon tape.

Method 2 - Flap Box

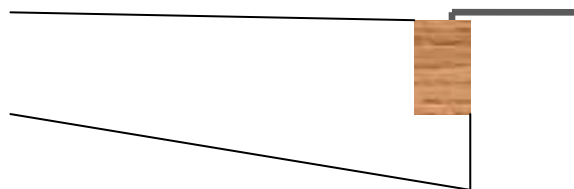

Build a box like typically used on the flaps. Combines the best of 1 and 2 for the cleanest look, but require more construction. If you use 1/6" sheet for the elevator, this may not be possible. On 3/32" sheet, you can use 1/32" plywood for the sandwich and 1/16" sheet inside.



The Stab and Elevator Hinge

If you have built other models, you can use the same technique for installing hinges. If you wish to spend more time on your model you can install regular small nylon or CA type hinges. If you use 1/16" sheet, these type of hinges are almost impossible to install. You must resort to the old fashion cloth or thread method.

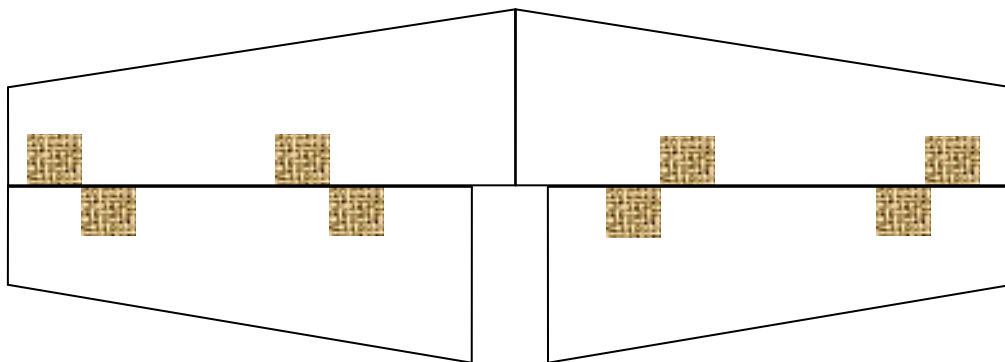

Iron On Hinge

My favorite type for 1/2A models are the cloth iron on hinge. They might be hard to find. If you are going to use iron on film on your model, you can use this for hinges. Please do not use CA type hinges. They are way too stiff for 1/2A models.



Iron the bottom inside joint first by folding it over on itself. After installing the hinges, cover the entire surface with the same film. For more strength, double up on the hinges before covering.

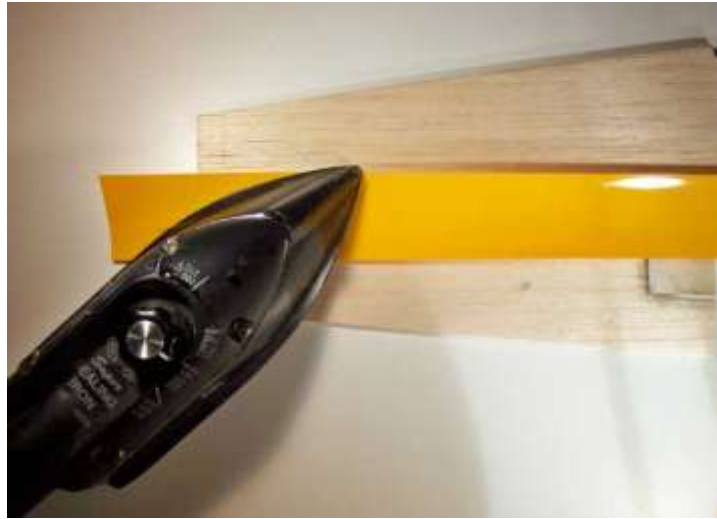

Refer to my web site under Tips for complete instructions or go to:
<http://www.scribd.com/doc/23753437/MonoKote-Hinge>

Thread Hinges

Thread hinges are another old hinging method. Use Dacron or even dental floss. These are very easy to do, extremely flexible and very long lasting. These are probably the hinges of choice for very thin control surfaces.

To make a thread hinge, mark hinge locations as you would if you were using a flat hinge and then sew a figure 8 pattern having about 6 stitches. Adjust the number of stitches based on how much strength is needed. Secure the hinges with glue

Assembly

Once you have the wing covered and stab and elevator joined and hinges together, it is time to install these to the fuselage. Proper alignment is the most important step in building a flyable model.

Optional Asymmetry

Some control line designers make the outboard wing shorter which will require less wing tip weight. I don't use any in my design, but if you want to do this, use only about 1/4" offset. Instead of trimming the outboard wing, just glue it with the center in the inboard edge of the fuselage.

Incidence

Incidence is the relationship between the wing angle and the angle stab. They should be zero zero . If you have an incidence meter use it.

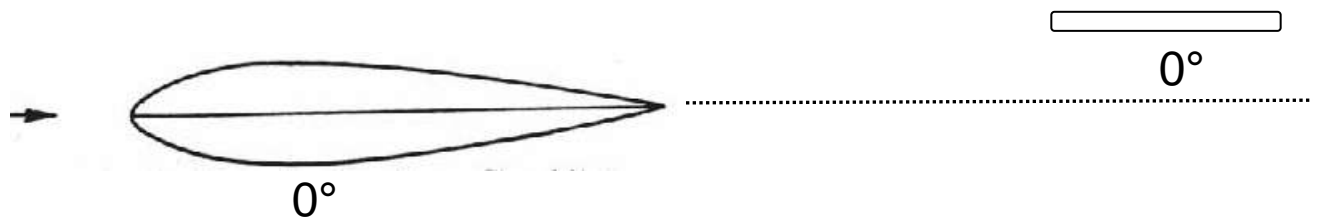

Square

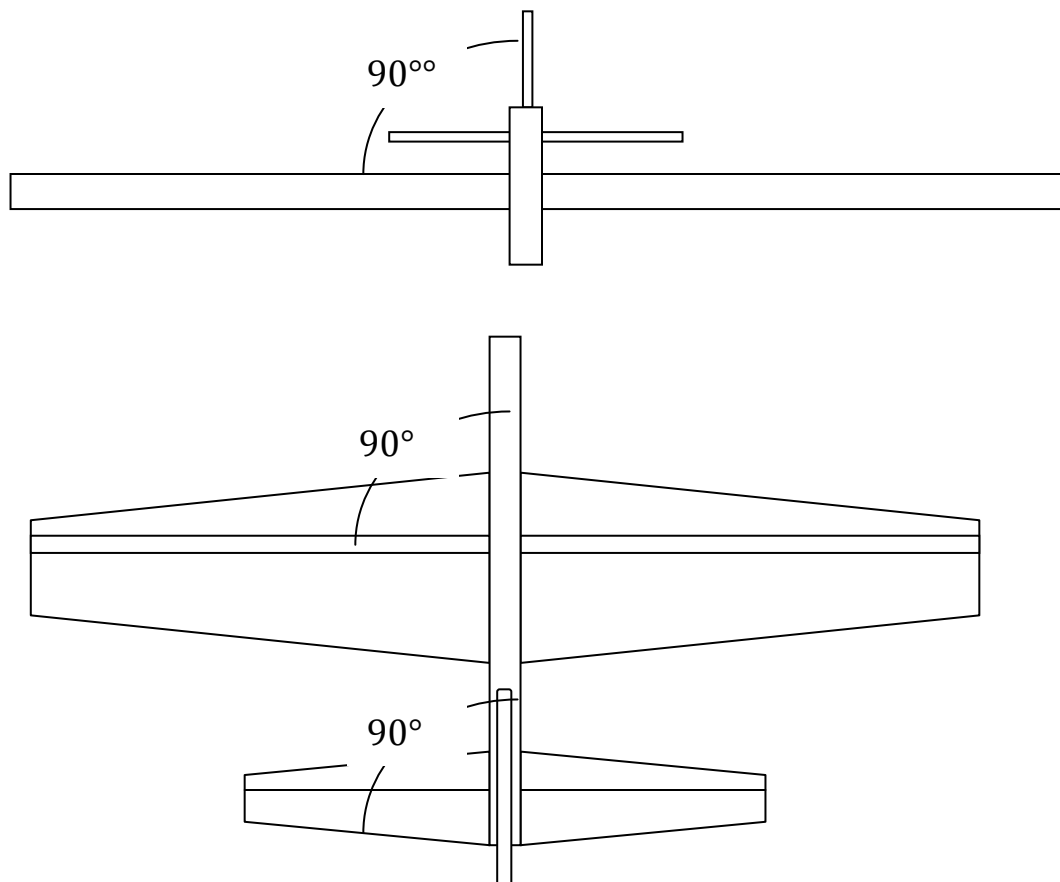

Rudder Offset

Right (or outboard) rudder offset is very frequently shown on plans to induce an outboard yaw that supposedly enhances line tension. Too much outboard rudder will make the airplane "doggy". Experience shows that very little rudder offset is desirable. You should just have enough offset angle that will ensure you that it isn't left (inboard).

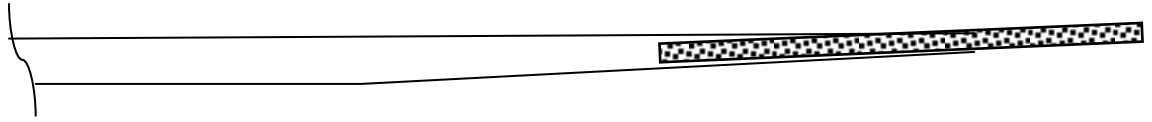

If you have tapered to inboard side of the fuselage toward to tail, just install the rudder straight. This will automatically give you just the right amount of offset.



Covering the Foam Wing



Prep for Covering

Lightly sand the wing cores with 320 grit and vacuum to remove all dust. Some people brush thinned Elmer's white glue in the foam to seal it. This will produce a better finish and allow the covering to stick, however it does add some extra weight.

I like to use a very thin coat of PolyCrylic which is a water base polyurethane finish used for finishing furniture. Another preparation option is to use

AquaNet hair spray. Spray the areas to be covered with AquaNet. It is only lacquer and is similar to using dope. AquaNet is also good for attaching any of the covering films.

Warning: Check for compatibility on a scrap piece of foam before using any kind of hair spray or glue.

Iron on Covering

Remember this is a foam wing, so you cannot use a high temp covering. Use low temp such as SLC or Ultracote and start the iron at 195 degrees. Cut a piece large enough piece for each the panel. Start ironing it down in the middle and work towards the edges. Try to stretch and smooth the covering as it is ironed to eliminate any wrinkles. Use the lowest heat you can to just get it to stick so the heat won't raise the foam texture. The covering can be heated and reapplied at least once if you are careless and iron in a wrinkle. Overlap the top covering by wrapping around the leading edge.

FasCal

This is an adhesive covering similar to packing tape. Do not remove the entire backing at once. If will curl on to itself and you will have a mess. Do the bottom wing panel first. I like start at the wing center and unroll the backing as you go, working out all wrinkles until you reached wing tips . It is a good idea you have a helper when doing this. Remember to overlap the covering. Wrap an inch around the top and visa-versa when you apply it on the top side.



Nelson LiteFILM

NELSON LiteFILM is perhaps the lightest iron-on covering film available. It weighs only .6 oz/sq.yd. (w/adhesive) while still durable and maintains its toughness. It comes in 13 = including 5 transparent. Supplied in 6 ft x 27 3/8" width.

Decals

Decals such as AMA numbers can be applied before covering if you are going to use transparent or clear covering such as SLC or FASCAL. I make my own water decals using decal paper from Micromark. I prep the area with thinned white glue so that the decal will adhere better. Soak the decal paper for only 15 seconds then wait 1 minute before attempting to slide the decal in place. More information about creating the decal using Microsoft Word software is on my web page.



Bellcrank and Horn

If you are using a store bought Nylon Half-A bellcrank set, it usually comes with a wood screw to attach the bellcrank. Throw it away. For a more secure mount use 2-56 machine screws with a blind nut behind the plywood mount.

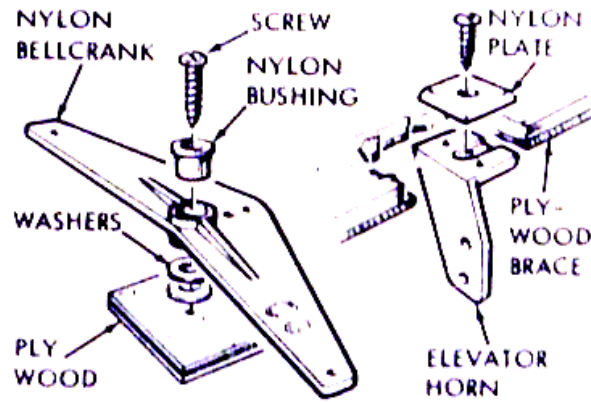

The Elevator Horn (optional)

Throw away the small horn that comes with the Half-A bellcrank set. It is too small for this size model. I like to use the ***Du-bro 1/2A Control Horn No. 107.***

This horn is a lot more robust and has 4 holes to adjust the sensitivity of the controls.

Circular Bellcrank (optional)

A circular type bellcrank will give your 1/2A model a more linear and control which will result in a smoother feel in the handle. It basically and small yoyo type device. Cut 2 larger rings and 1 smaller ring on a scroll saw. Epoxy the 3 piece together like a Yoyo with the smaller ring in the middle.

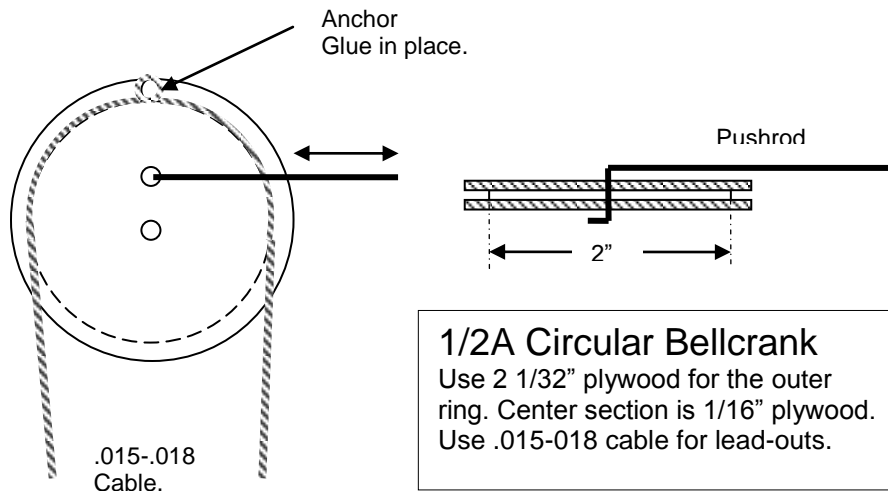

Install the Elevator Horn



Make sure you install the horn on the bellcrank side, which is the inboard side. The horn is installed on the bottom and secured with a nylon retainer on the top.

The Pushrod

Use 1/16" or .062 K & S steel wire for the pushrod. Connect to the top of the bellcrank with a Z-bend. Connect from the top give you the least amount of resistance, but if you do not have a Z-bend tool use an L-bend and attach from the bottom. Add a Z-bend in the middle for adjustment.



Carbon Tube



For an even stiffer pushrod you can use a .125 carbon tube with R/C type clevis on the ends. The clevis are generally not recommended for control line, but a 1/2A model don't have the same forces as a .40-.60 size model.

I use 2-56 size clevis for the ends. Cut the clevis rod down to about 2" and



epoxy it into the carbon tube.

Warning:

When cutting the carbon tube, wear a face mask. Mask

the area to be cut with mask tape. This will prevent splitting. I like to bend the very end of the rod so it insert tightly into the carbon tube. Mask the area before gluing. Use epoxy or JB weld to glue the rod into the carbon



CG (Center of Gravity) and Lead Out Position

Go you my web site, click on Tips and read Brett Bucks article, *Bench Trimming a Stunt Ship*.

<http://aeromaniacs.com/Tips.html>

The mode as a Stab/Elevator to Wing ratio of 20%, therefore 20% of MGC (Mean Geometric Chord) or average chord. If this is beyond you, read the article first.

Here are the numbers for this model:

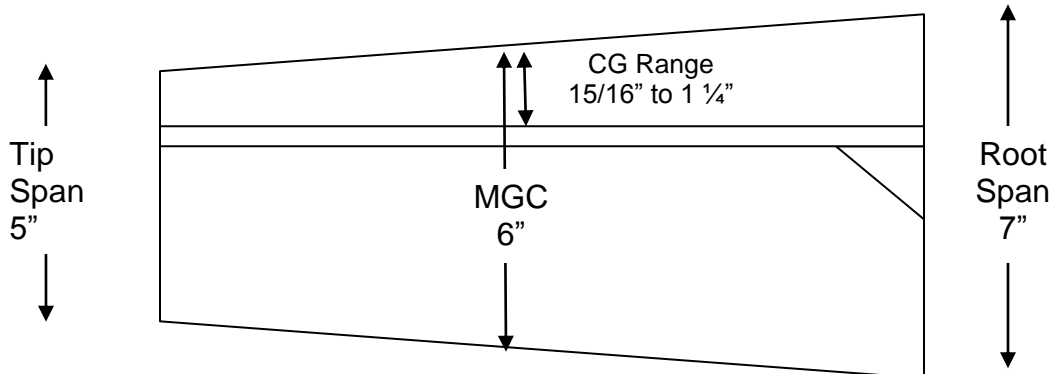

$$\text{MGC} = (7" + 5.25") / 2 = 6 \frac{1}{4}"$$

CG Upper Limit @ $20\%/100 \times 6.2" = 1 \frac{1}{4}"$ (more sensitive)

CG Lower Limit @ $15\%/100 \times 6.2" = 15/16"$ (more stable)

That mean the C.G should measure about 15/16 to 1 1/4" from the leading edge if taken at the middle of the wing. The more aft the C.G the more sensitive the controls. Conversely the more forward the more stable the model will fly.

Lead Out Position

On larger stunt model the lead out position or sweep is calculate 1.5 to 2.5 . behind the C.G. from the center of the wing. The lead out position is related to the C.G. If you more the C.G. 1/8" forward you must do the same to the lead out position. That is why you need to make it adjustable.

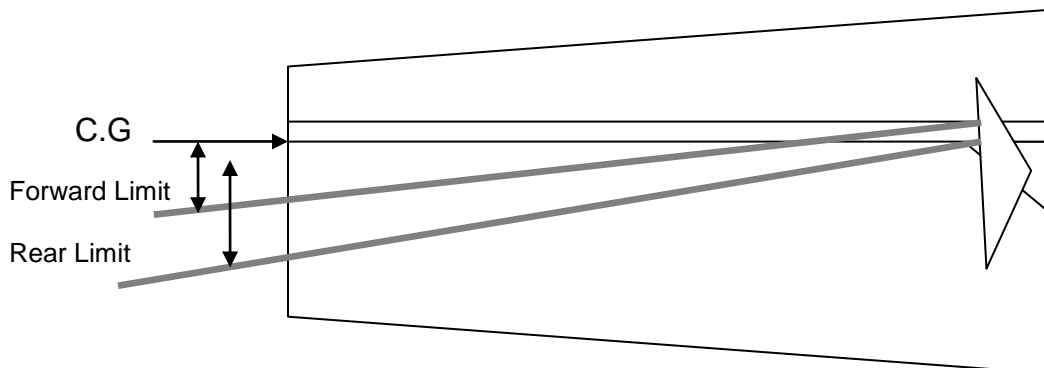

Forward Leadout Limit = $15'' \times \tan(1.5^\circ) = .39 = \mathbf{3/8''}$

Rear Leadout Limit is = $15'' \times \tan(2.5^\circ) = .65 = \mathbf{5/8''}$

What does this mean? The forward a rearward limits does not mean the position of forward and rear leadouts. It just mean that the center of the 2 leadouts should be within this range. A good rule is simply $1/2''$ rear of the C.G. is a good start for most 1/2A stunt models.

Wing Tips

Use the wing tip as a template to create Inboard and outboard wings tips.

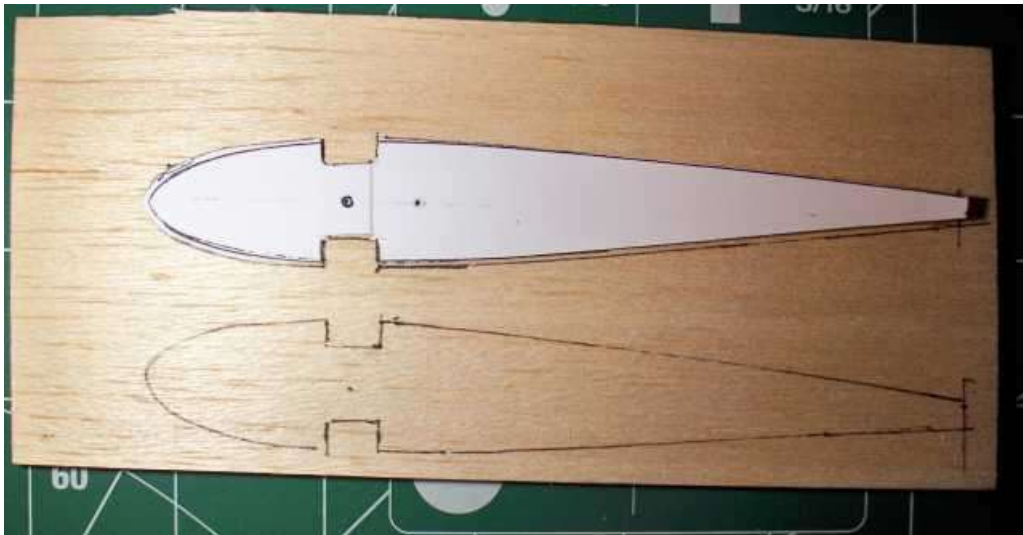

The position of the leadouts guide should be between the calculated forward and rear limits.

Tip-weight

Weight in the outboard wing-tip is almost always required. This weight compensates for the weight of the lines and corrects any construction imbalances. If the design contains wing asymmetry less tip-weight is required than if you have equal-span wings. The theory is that the fuselage being off-center acts as tip weight. A good starting point on this model is about 3 pennies or $\frac{1}{4}$ oz of lead. On some single gear models, I put the 2nd wheel gear on the tip to save weight.

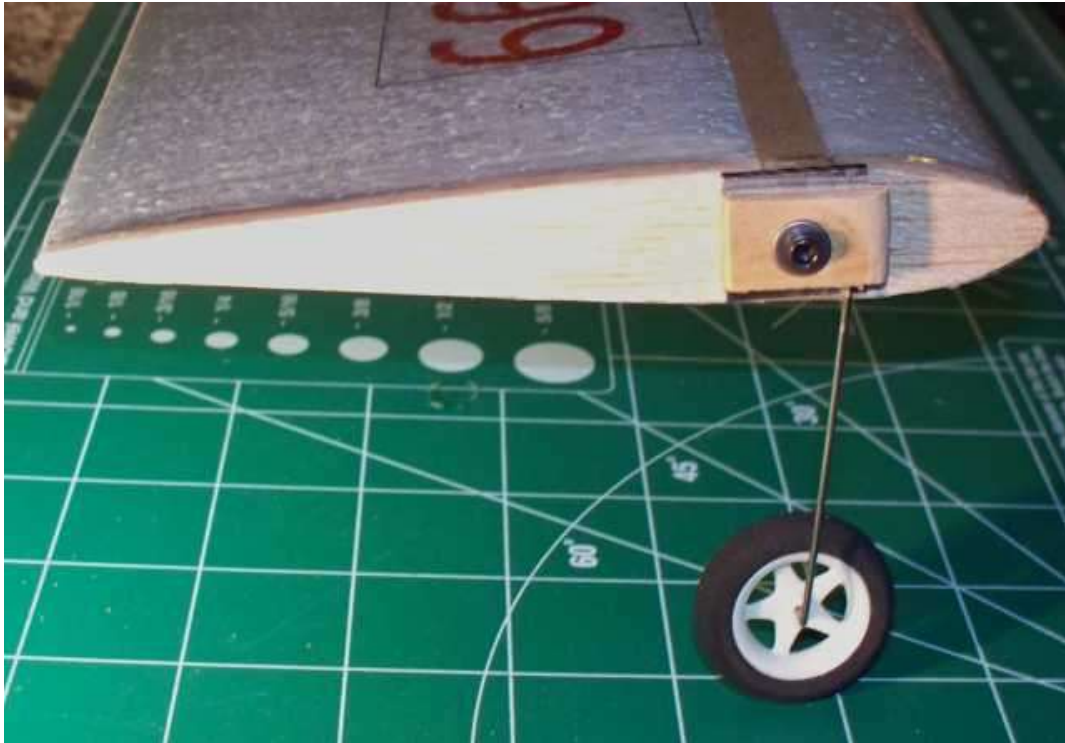

Sometimes a trim tab might need to be installed on the outboard wing. This is to correct any warp in the wing. Warps will cause the model to either outboard wing high or low. Some people may say this is a tip weight issue. To determine whether this is a tip weight or warp problem, you need to fly the model inverted. For example, if the wing is high upright and low inverted, it is a wing warp issue. To correct this you need to have an outboard tab in the up position as pictures in the photo.

Adjustable Leadout Guide

Now that we have calculating the start point for the leadout position, it is a good idea to make it adjustable.

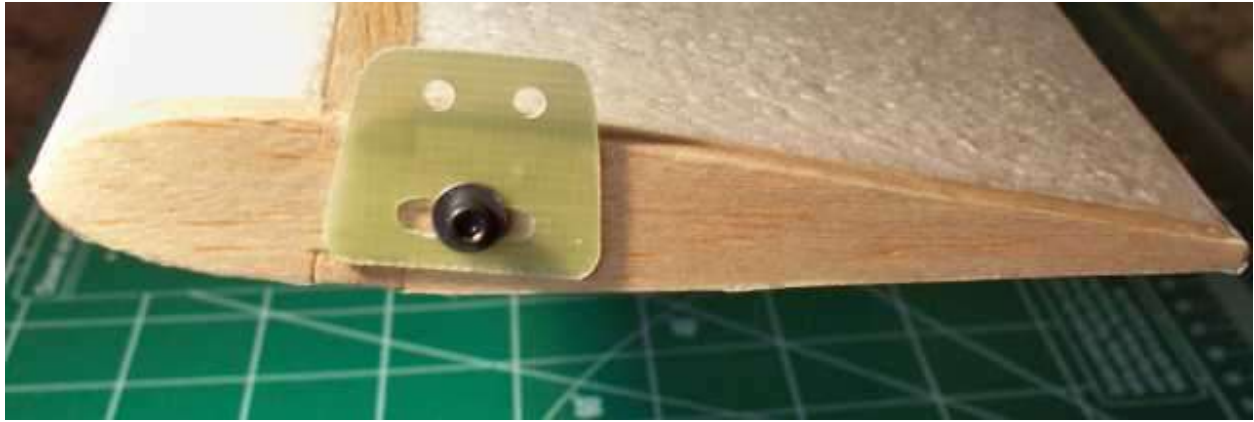

Make the wing tips using soft ply or 1/16" hard ply. Center the leadout post about 1/4 aft of the calculate C.G. The one to the picture could be position more aft. This will allow you to make adjustment at the field.

Engine Mount

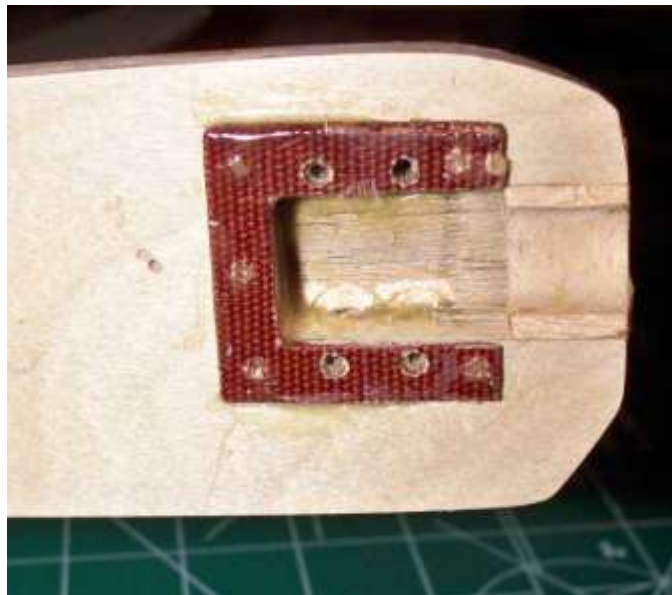

I've installed a phenolic engine mounting pad. You can use any material such as plywood or aluminum. If you do not install a pad you might have to route out the area in the mount where the bottom of the crankcase might touch.

Notice the nose plug which can be easily glue it using some scrap balsa. This make a cleaner looking nose.

Mounting the Fuel Tank

It is important that you mount the tank so it can be adjusted in the vertical direction (up and down). The simplest method is this rubber band type mount. Allow at least 1/8" play in either direction for tank height adjustment.

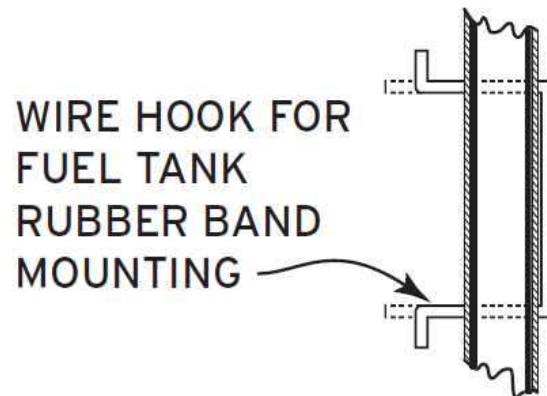

I make a tank mount using either phenolic sheet or 1/16" plywood. The tank can be glued with Polyurethane glue (Gorilla Glue).

Make a mounting pad using the same dimensions and add blind nut to the back. This is then glued behind the engine. The tank position should be on the center line of the engine. I like to add a shim to angle that rear of the tank outward. This will insure that every drop of fuel is used up. It also aid in a better engine cut-off and the end of the flight.

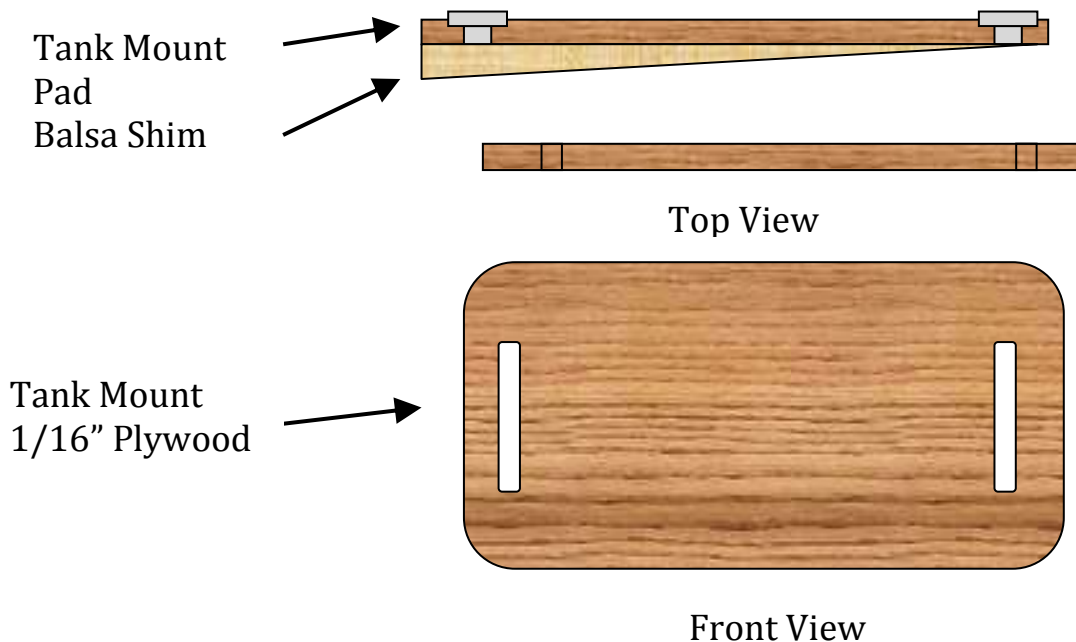

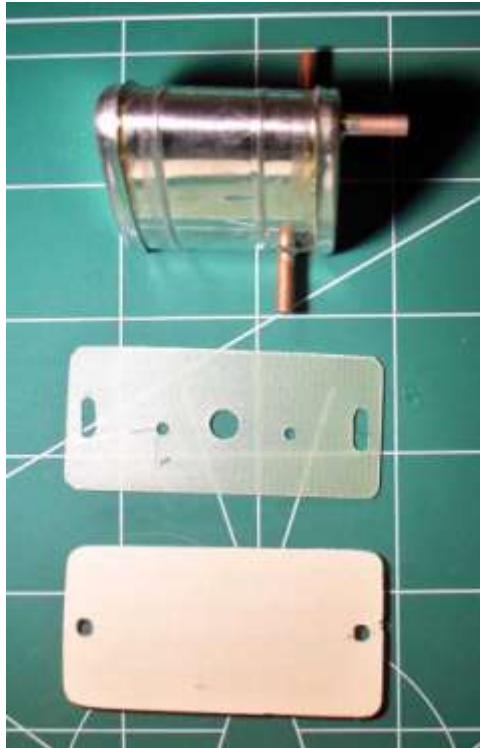

Glue the tank to the mount using J. B. Weld epoxy glue.

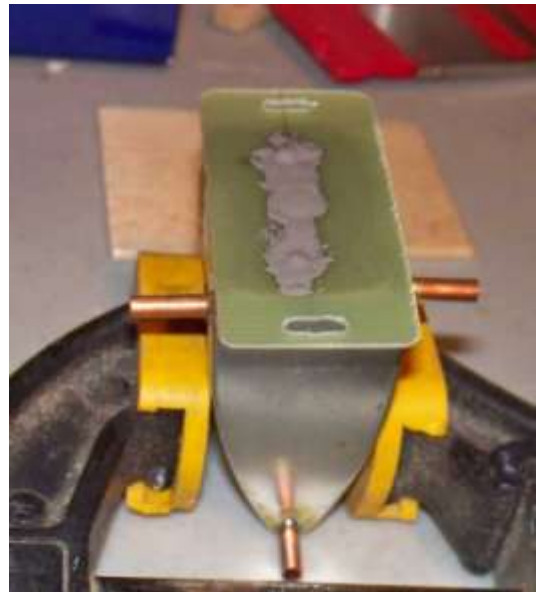

It drilled holes in the mount to insure better adhesion. Put enough glue so that it pushes through. Smooth out the glue.

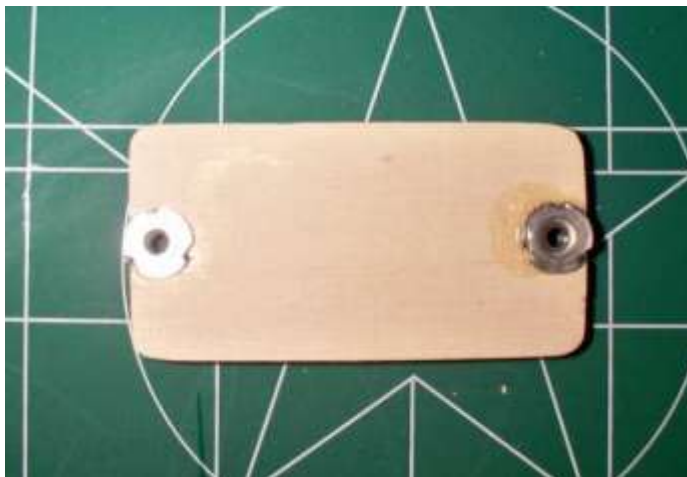

Left: Install blind nuts to the back of the tank mounting pad.

Note: This can be installed on the inboard doubler instead.



Fuel Tank

. I use a ***Brodak #BH521 1.0 oz. standard vented tank***. This will be the perfect size for Norvel or AP Wasp type engine. A Cox eeDee or Medallion may require 1.5-2.0 oz's to complete the entire pattern. Brodak makes a Pinto tank which was designed for these engine.

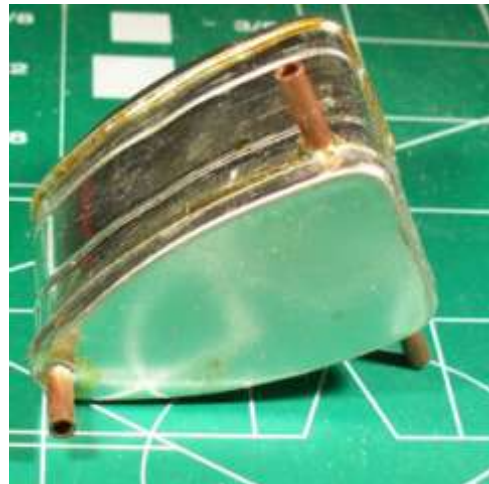
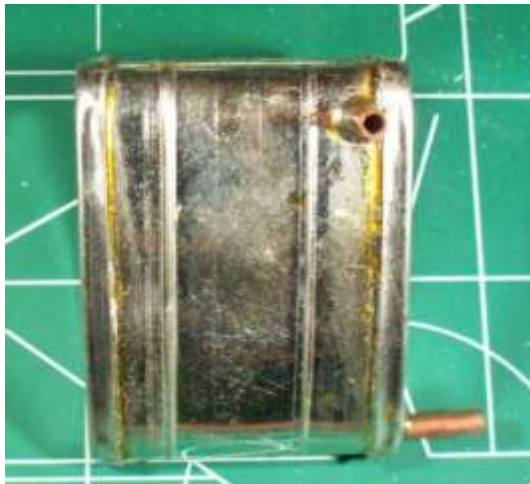

Making a Uniflow Tank

The secret to a consistent stunt run especially for the Norvel BigMig engine is the uniflow tank setup. Since they do not make a uniflow 1.0 oz. tank, I use a

standard vented tank and solder a 1/8" diameter copper tube facing toward the airflow of the propeller.

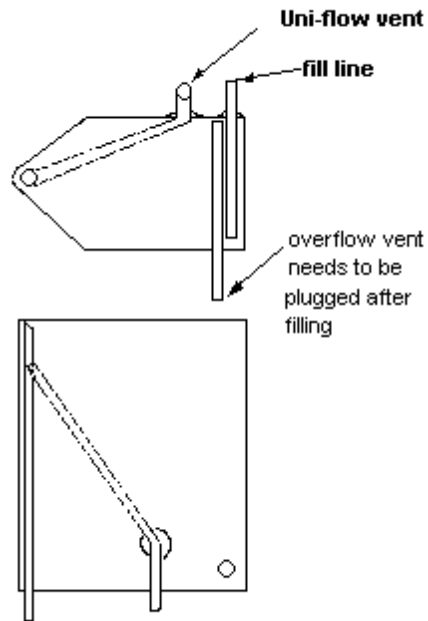

Position the uniflow vent just 3/16" - 1/4" in front of the fuel pickup tube as shown in the diagram.

Finishing

If you decide to use iron on covering for the entire model, I suggest leaving the engine doubler area for painting with some type of fuel proof finish. After covering the remaining fuselage, fill the area between the wing and fuselage with epoxy or any epoxy base fillet. If you are painting the fuselage, put the fillet first. Remember that the secret to a good fillet is the mask about 1/8" around the wing on both sides.



Engine

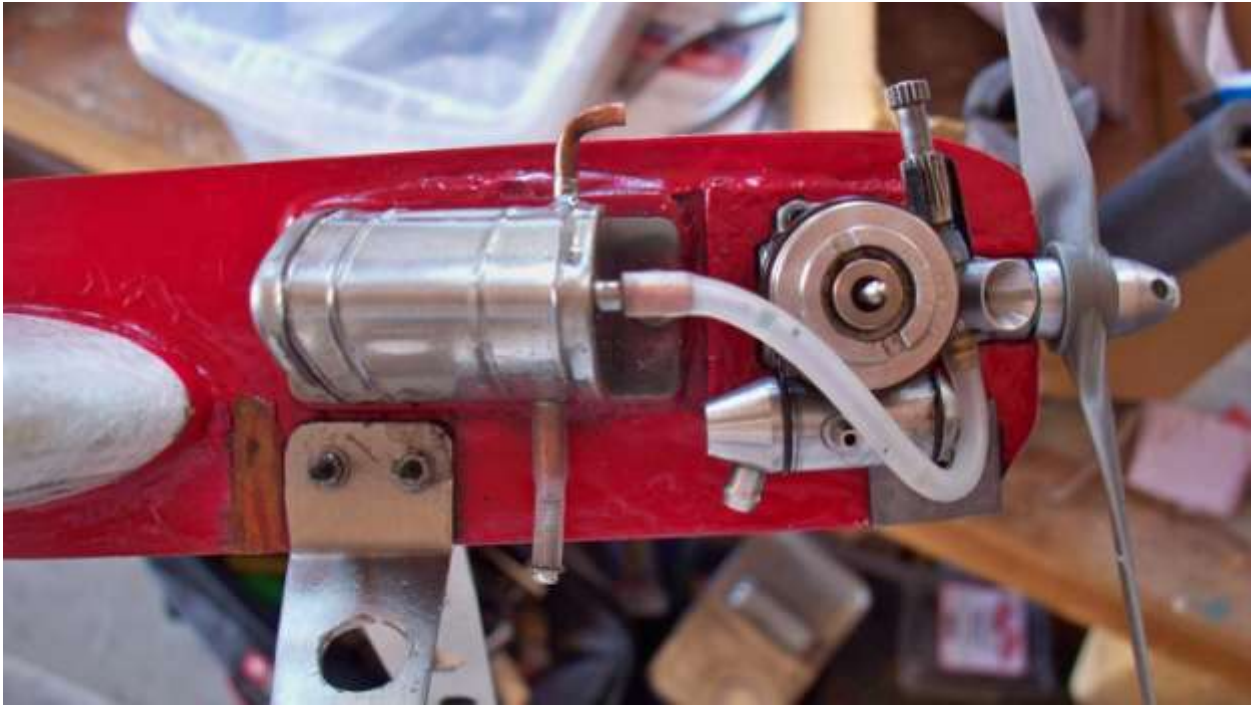

This model is designed for high performance .049 - .061 size engine. A Cox Tee Dee would be the minimal power plant. I prefer the Norvel BigMig .049, not the AME combat engine. The AME can only be used with a bladder or pressure fuel system.

I have been very successful in using Norvel BigMig .049 engine for stunt. I found that this setup will give you an optimal run for the 6 minutes need to complete a AMA pattern. Do not use stock muffler pressure setup that comes with the engine. The secret is uniflow vent.

Norvel Setup

- Brodak BH521 1oz tank modified with a 1/8" uniflow vent. Vent uniflow tube forward to airstream. I'm finding that short length tanks work the best.
- Start with at least 3 head gaskets
- Use a SM (small medium) fuel line - Sonictronics #225R
- Prop: APC 5.5 X 2.5 or 6 X 2 propeller
- Launch at about 18.5K RPM (the lower the nitro the higher the launch RPM)
- Fuel: 15 - 20% nitro is all you will need. Synthetic blend with at least 18% oil seems to work the best. Too much oil degrades performance.

Recommended Engines



- Norvel BigMig (Not AME) .049, 061
- Cox Tee Dee .049, 051 (modification needed)
- Cox Medallion .049, 051
- Brodak MkII .049, 061
- AP Wasp .061
- VA .049 (Must raise head height)

Note: Some of these engines require modification to work with standard suction type tank.

Tank Height

Tank height is about the center line of the needle valve with the muffler. However, if you do not run it with the muffler, I found that the tank height may need to be raised another 1/8".

Note: Use a 1/8" slice from medium silicon fuel tubing as a bushing for APC's props.

Flying Lines

For serious stunt flying, use .008 steel cable. Some flyers have been successful use 14lb. Spider Wire type fishing line, but this is not permitted in contest, I use 42' to 45' with a Norvel .049 and even up to 52' with a .061 engine.

Note:

The first build of this model I used the single wire gear with the outboard tip gear to save weight. I found the adding 1 more oz to the model did not degrade its performance. It may have even made it fly more stable. I actually use a .15 size aluminum gear which was drilled out. The final weight of the model was still under 12oz.

Control Handle



To get maximum feel and control of your 1/2A stunter, use a control handle designed for 1/2A models. Do not use a full size control handle. It is important the handle is light as possible. I like to use the Sig 1/2A Control Line Handle (left). You can use the outline of this design to cut one out of 1/8" plywood. Start with a 2" spacing on the handle.



Update:

This model took 1st place in Sportsman Profile and 3rd place in Advanced PA at the 2012 Northwest Regional's.

Have fun flying!

Heman Lee

www.aeromaniacs.com