

Aero artistic Free style



Specification:

- Wingspan: 74".0 in (1880mm)
- Overall Length: 68 inches No spinner length
- Wing Area: (80 m2)
- Flying Weight: 10.5 - 12.1 Lbs (4.8 - 5.5 kg) dry
- Engine Size: 30cc-35cc Gas .YS 140 ,E power
- Motor: Hacker A60-22S
- ESC: Jeta/Hacker 99A
- Battery: Flight Power 3700-10S or 4250-10S
- Propeller: APC 20x10E

code No. xcA004

For intermediate & advanced fliers.

INSTRUCTION MANUAL

pro *AK* **35cc**

**RADIO CONTROLLED ALMOST READY-TO-FLY ENGINE&ELECTRIC POWERED
Total Area Vacuum Sandeich Technlolgy AEROBATIC PLANE**

INDEX

REQUIRED FOR OPERATION	2
BEFORE YOU BEGIN	3
ASSEMBLY	3-10

*please read these instruction carefully and thoroughly before assembling your pro *AK* to achieve safe operation methods and maximum performance.*

REQUIRED FOR OPERATION (PURCHASE SEPARATELY!)

1 Engine and Muffler

Model Airplane Engine

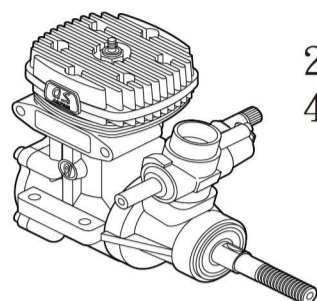

2-cycle 90-108
4-cycle 120-140

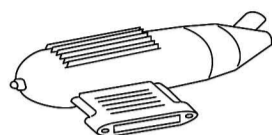

Muffler

2 Propeller and spinner

Purchase a propeller than will match your engine.

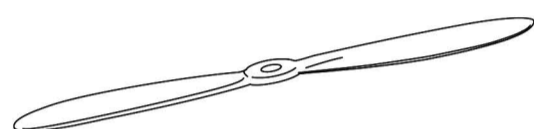

Propeller

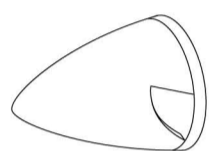

spinner (76mm)

3 A minimum 4 channel radio for airplane(with 6 standard servos),and dry batteries.

CAUTION: Only use a minimum 4 channel radio for airplanes!

(No other radio may be used!)



A minimum 6 channel transmitter for airplanes.



2 extension cords



1 Y-harness

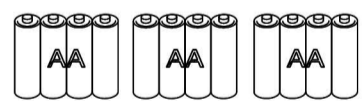

12 AA-size batteries

4 Glue

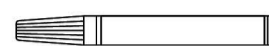

Instant Glue



Epoxy Glue(30 minutes type)

5 Fuel Tank

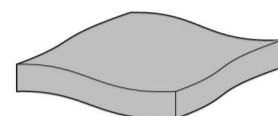

Sponge Sheet



Silicone Tube

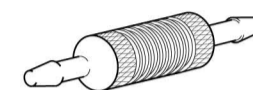

Fuel Filter

6 Other equipment for enhancing airplane operation & performance

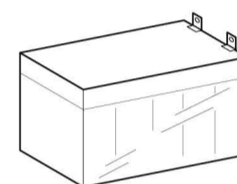

12V Battery(for starter)

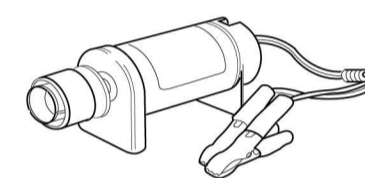

Engine Starter

7 Required for engine starting:

WARNING: Normal gasoline cannot be used with glow engines.

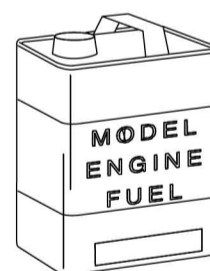

Gas engine fuel only

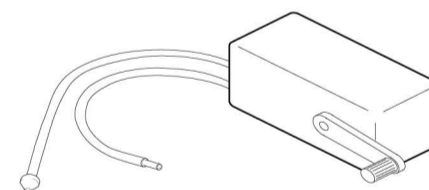

Fuel Pump



Spark Booster Battery set

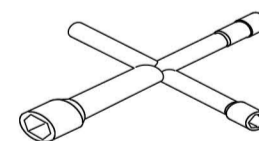

Plug Wrench

Glow starter Charger

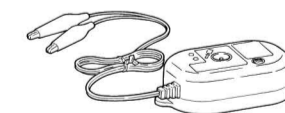

TOOL REQUIRED (PURCHASE SEPARATELY!)

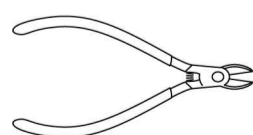

Wire Cutters

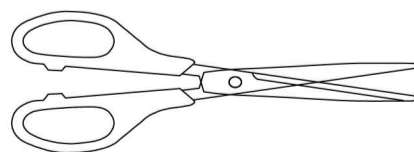

Scissors

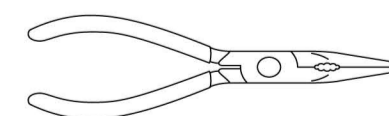

Needle Nose Pliers

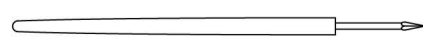

Awl



Phillips Screw Driver(L, M, S)



Sharp Hobby Knife

BEFORE YOU BEGIN

- 1 Read through the manual before you begin, so you will have an overall idea of what to do.
- 2 Check all part. If you find any defective or missing part, contact your local dealer.
- 3 Symbols used throughout this instruction manual, comprise:



Pay close attention here!

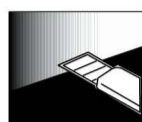

Cut off shaded portion.



Drill holes with the specified diameter.



Must be purchased separately!



Apply instant glue (C.A glue, super glue).



Assemble left and right sides the same way.



Cut off excess.



Apply epoxy glue.



Ensure smooth non-binding movement while assembling.

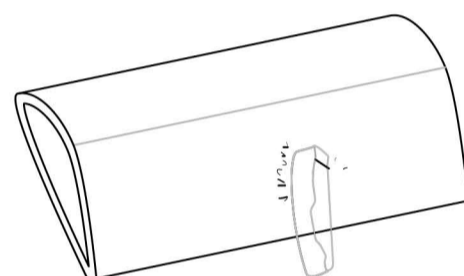

with Polishing Cloth

1 Main wing

Securely glue up and soaked up the hing with instant glue (low viscosity type)

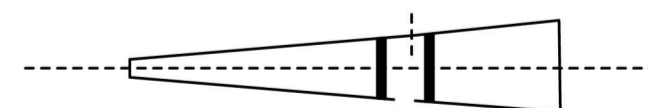
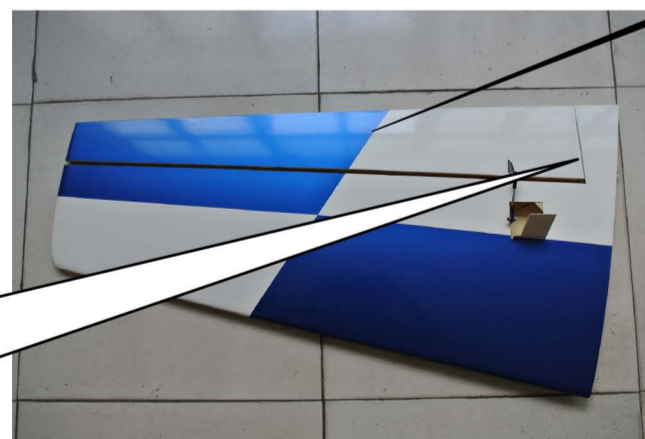
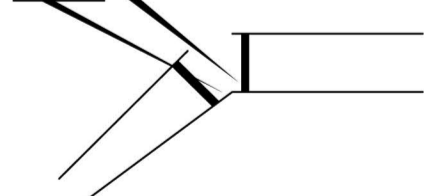

Align the center line of main wing with aileron.



4 Main wing

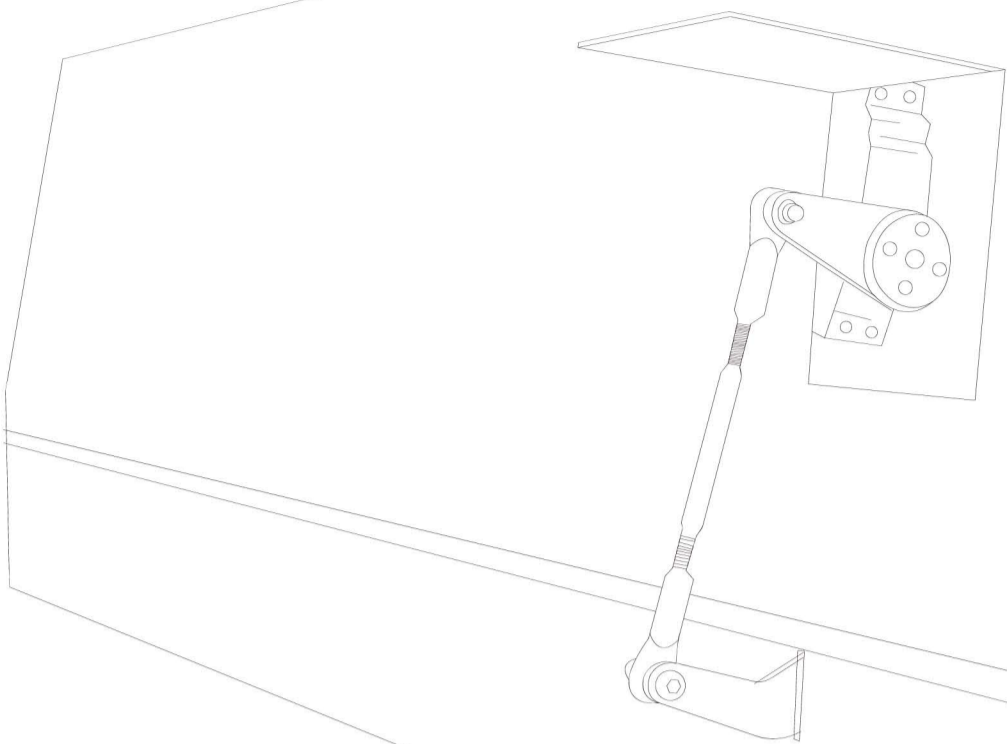

5 Main wing



6 Assembly of the fuel tank.

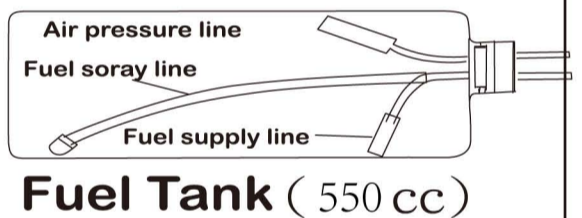
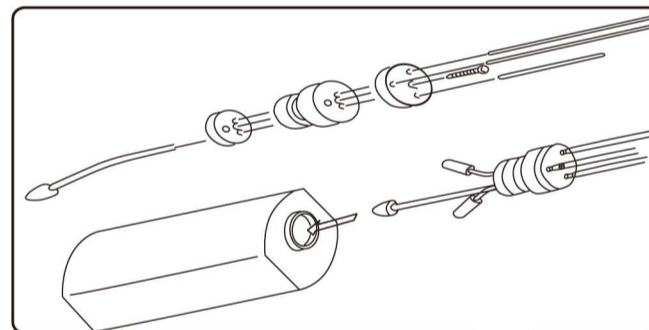

Fix with silicon glue.

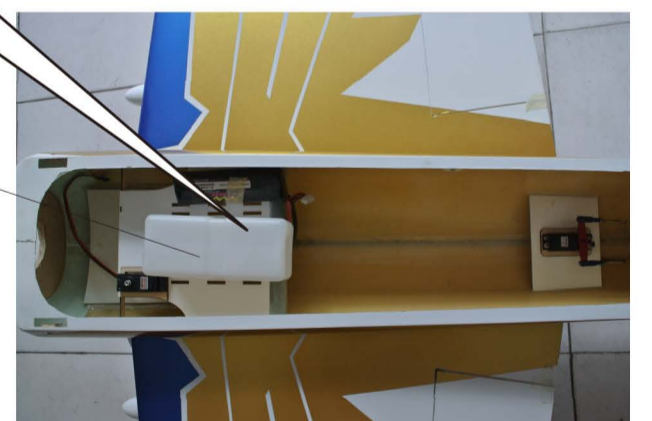

Mount the fuel tank into the fuselage.



Pay close attention here!



Cut off shaded portion.



Drill holes with the specified diameter.



Must be purchased separately!



Apply instant glue (C.A glue, super glue).



Assemble left and right sides the same way.



Cut off excess.



Apply epoxy glue.



Ensure smooth non-binding movement while assembling.

7 Engine mounts, Throttle Rod



 Before installing the engine mounts, place the engine onto the mounts and make four 2mm holes.

 Engine thrust on balk head is already adjust at factory.

8 Main wing

Warning! Securely attach the main wing. If coming off during flights, you lose control of your airplane which leads to accidents !

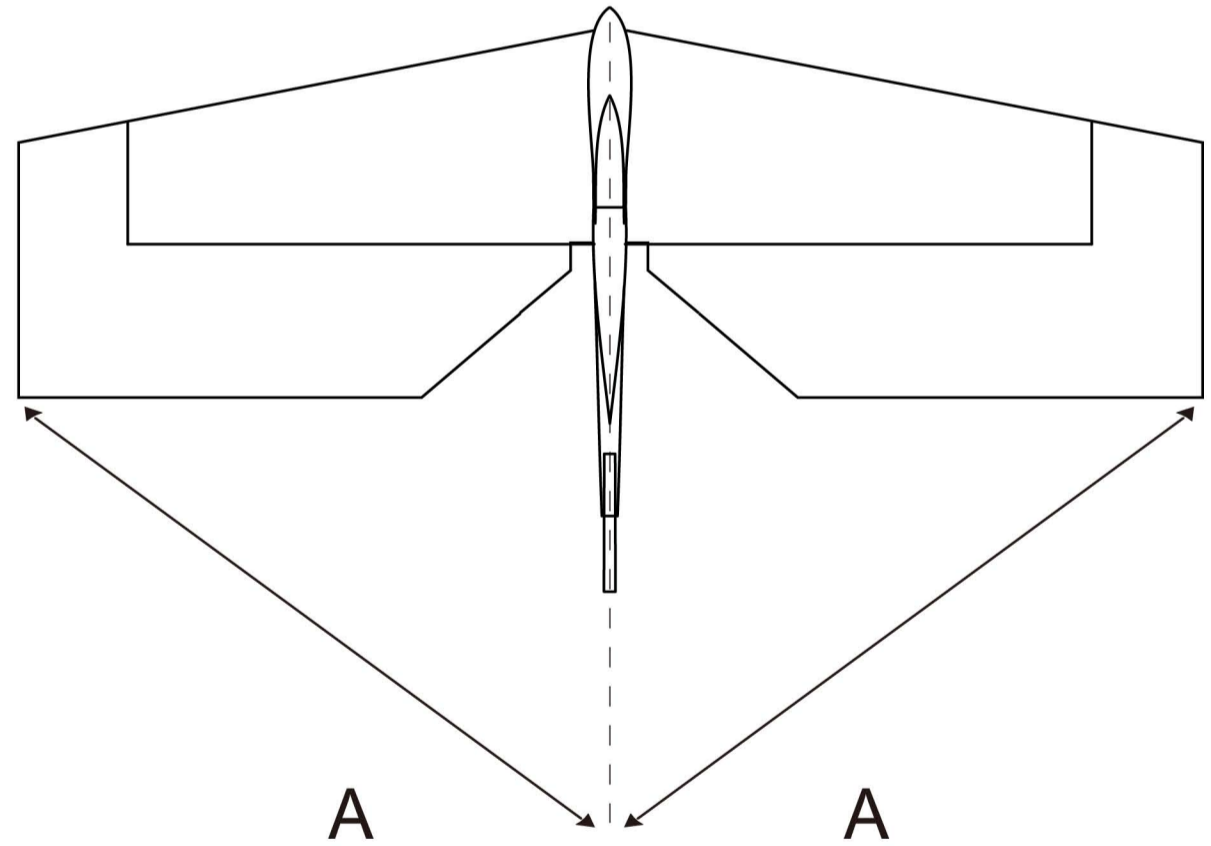
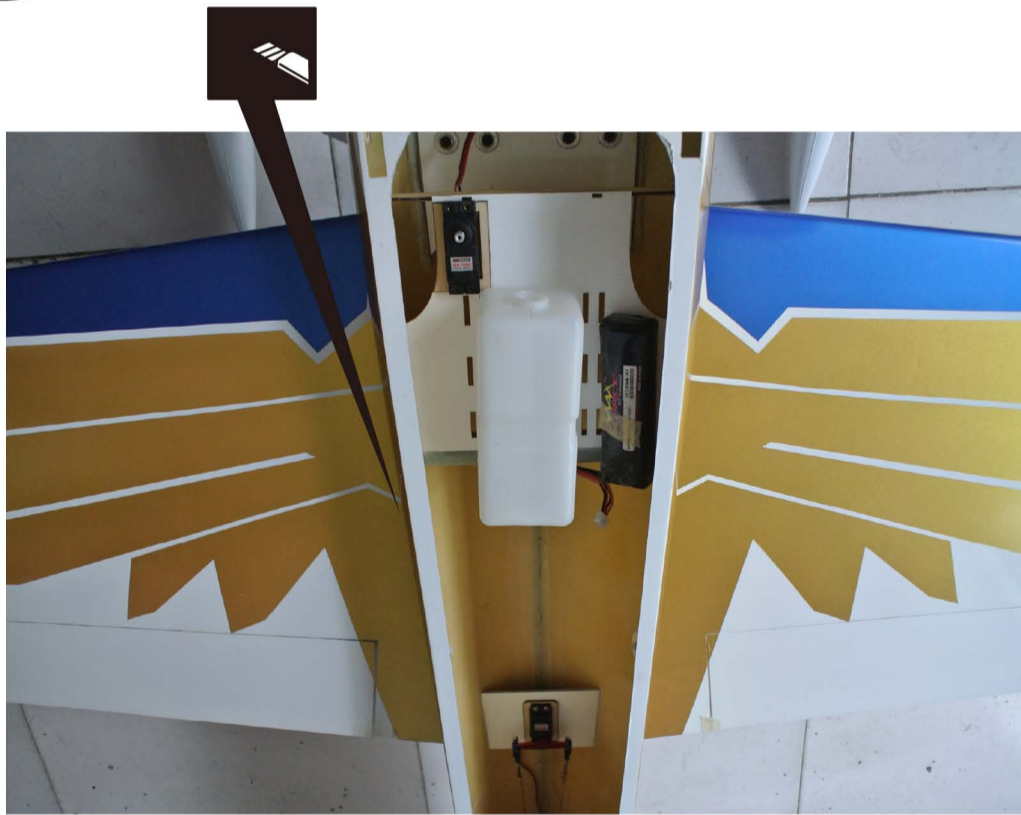

 A=A,

 Pay close attention here!

 Cut off shaded portion.

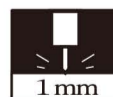
 Drill holes with the specified diameter.

 Must be purchased separately!

 Apply instant glue (C.A glue, super glue).

 Assemble left and right sides the same way.

 Cut off excess.

 Apply epoxy glue.

 Ensure smooth non-binding movement while assembling.

9 Vertical / Horizontal Tail

Warning! Securely glue together. If coming off during flights, you lose control of your airplane which leads to accident!

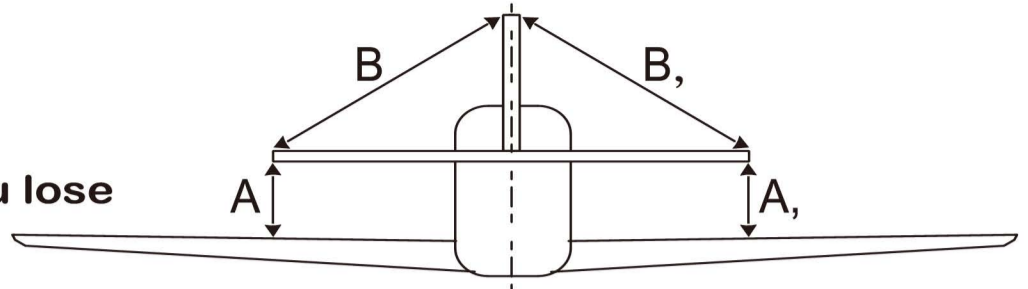

! A = A, B = B,
C = C, D = D,

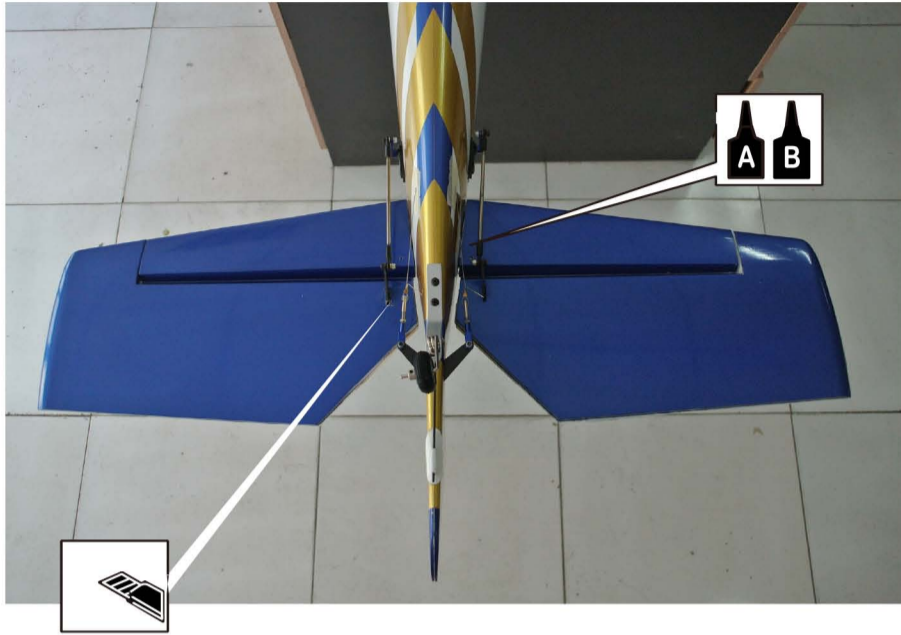

Cut away only the film.

Feel for the edges of the holes under-neath the film. Then, cut away the film along the edges.

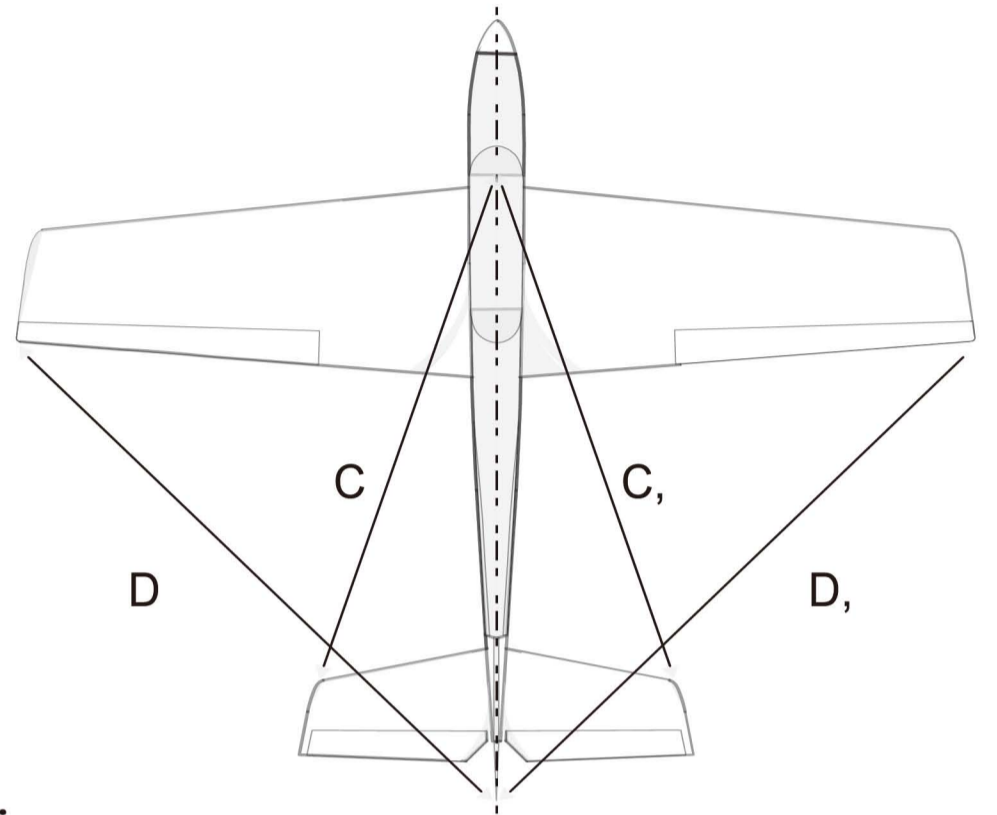

10 Vertical / Horizontal Tail

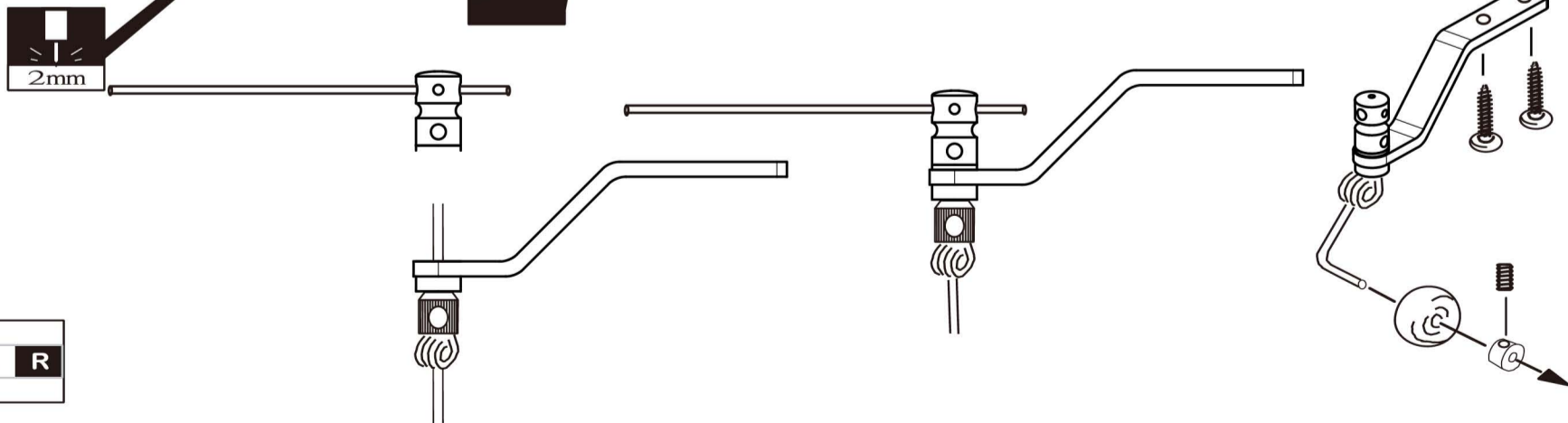
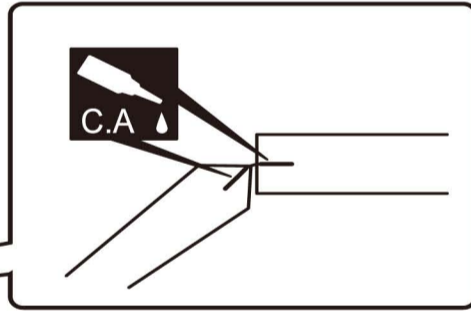
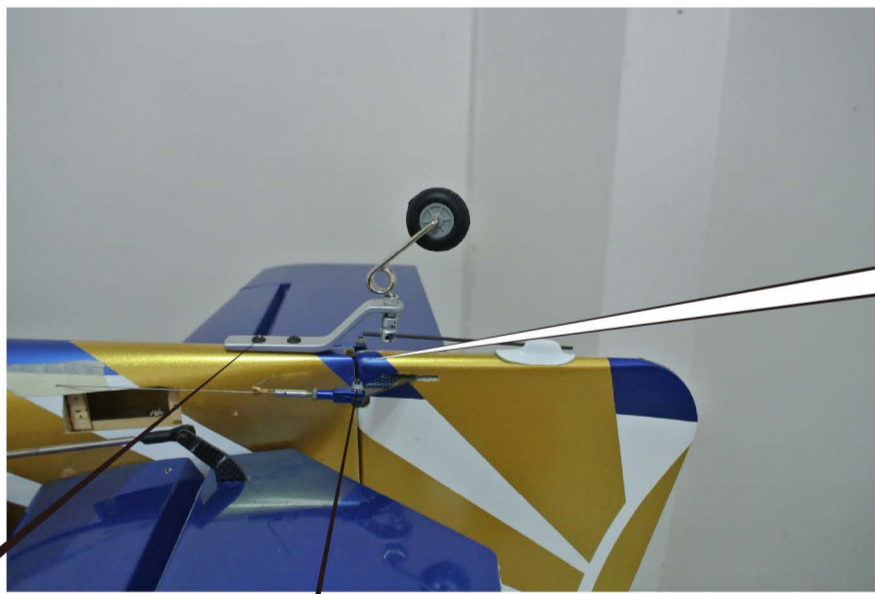

	Stopper (s)	2
	3*4mm Set Screw	2
	2.5*12mm TP Screw	2

Cut off excess.

Apply instant glue (C.A glue, super glue).

Ensure smooth non-binding movement while assembling.

Drill holes with the specified diameter.

11 Canopy, Cowling

Cut away the surplus parts of plastic cover carefully along the shaded line.



It is also possible to fix the canopy with silicon with screw.



Apply instant glue into screwed hole to make reinforcement.



12 Radio Equipment

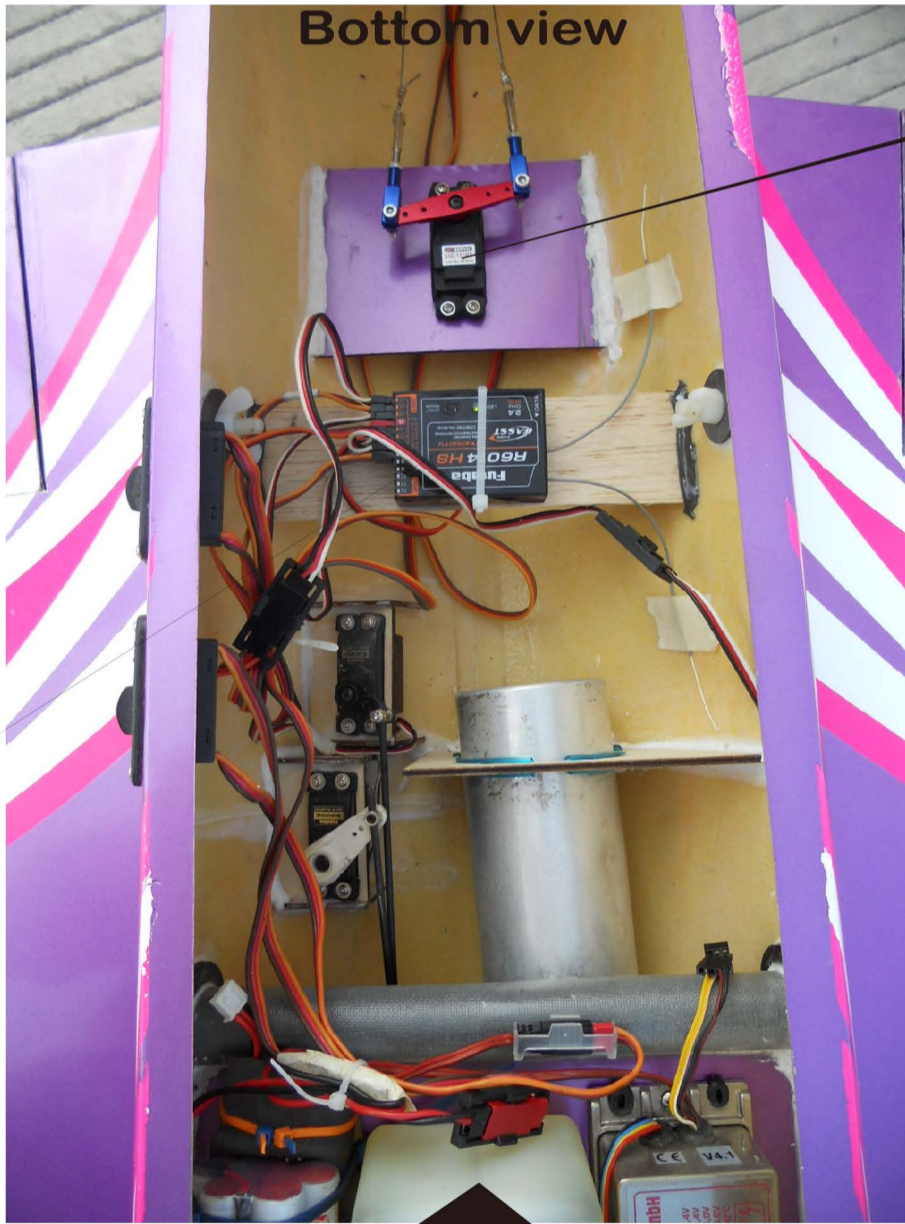
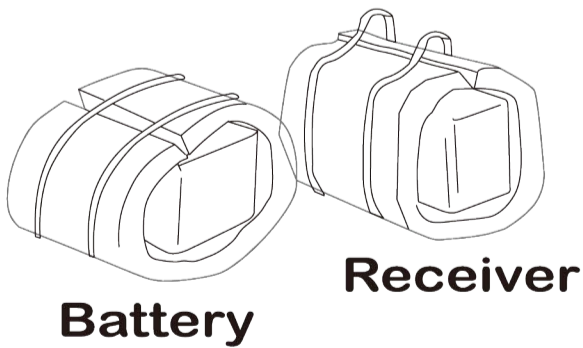

PS Rudder Servo



Pay close attention here!



Cut off shaded portion.

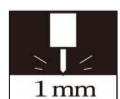

Drill holes with the specified diameter.



Must be purchased separately!



Apply instant glue (C.A glue, super glue).



Assemble left and right sides the same way.



Cut off excess.



Apply epoxy glue.



Ensure smooth non-binding movement while assembling.

13 Rudder

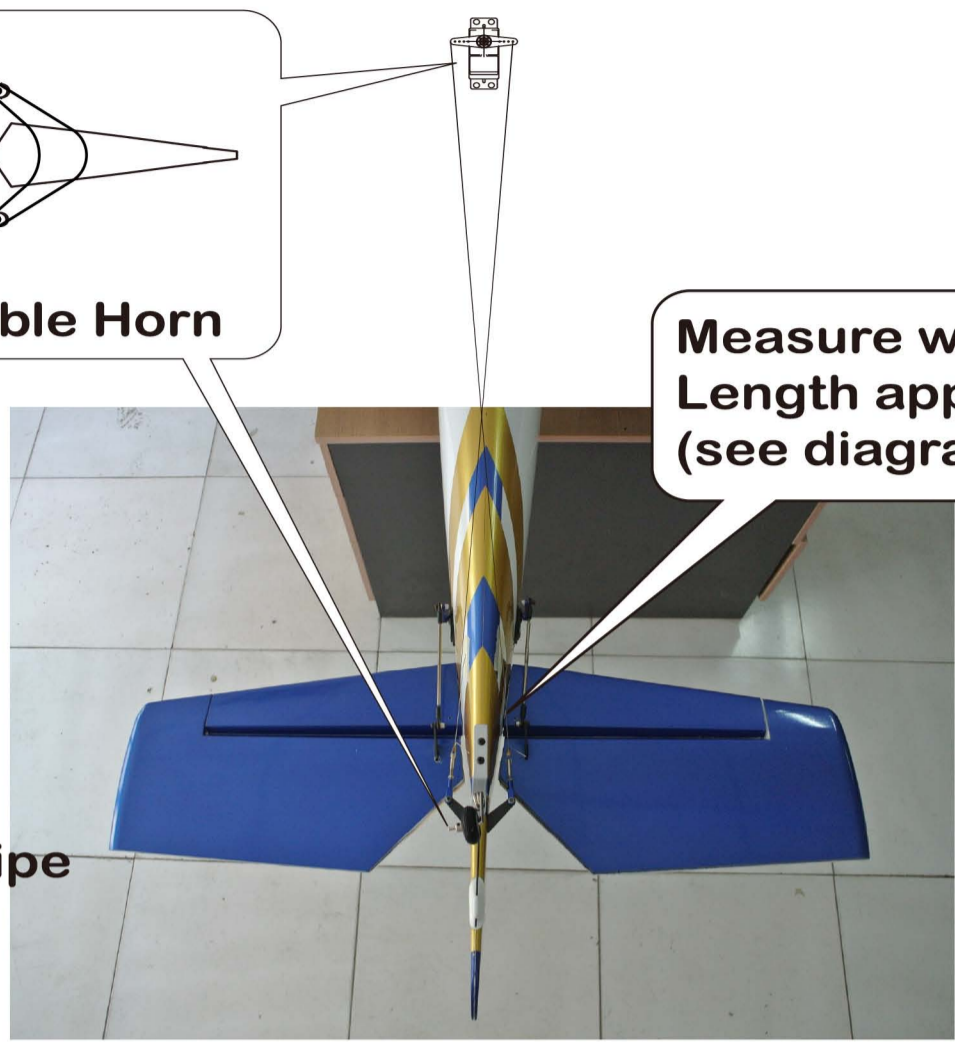
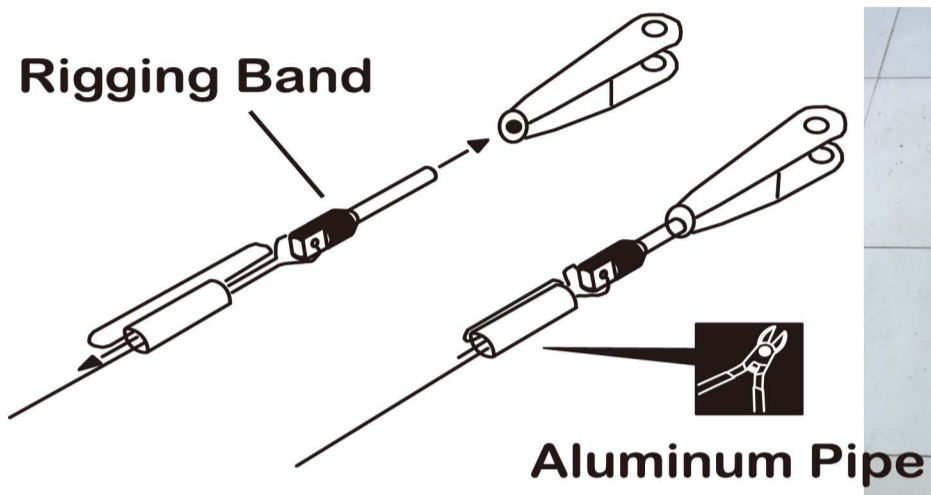
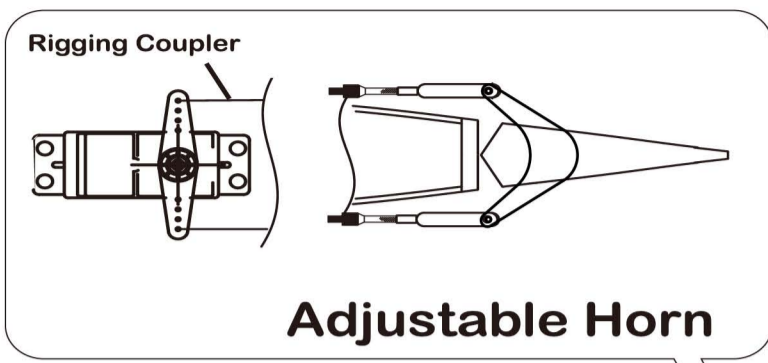

Measure with for proper fitting
Length approximately 10-20mm.
(see diagrams)

14 Elevator

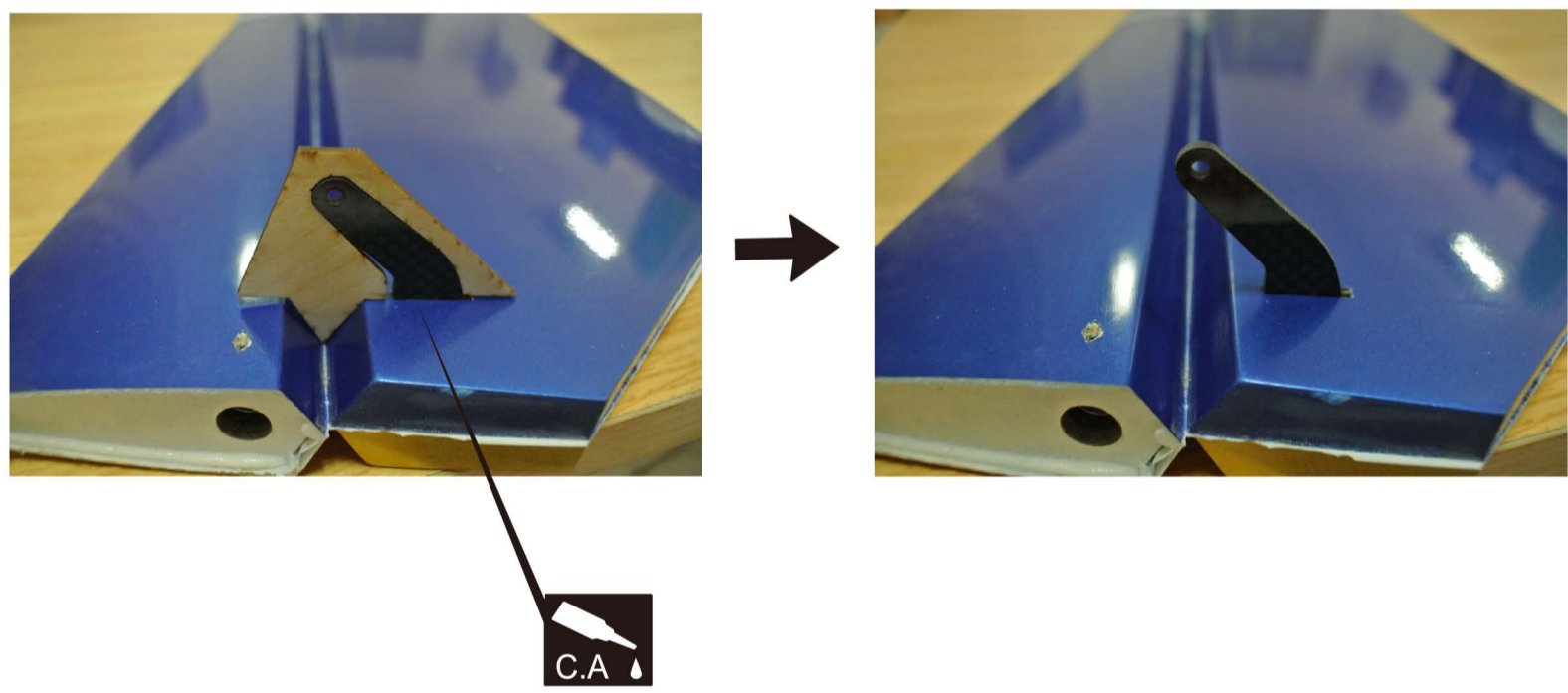

Pay close attention here!



Must be purchased separately!



Cut off excess.



Cut off shaded portion.



Apply instant glue (C.A glue, super glue).



Apply epoxy glue.



Drill holes with the specified diameter.



Assemble left and right sides the same way.



Ensure smooth non-binding movement while assembling.

15 Main Landing Gear

Attachment of the main landing gear.

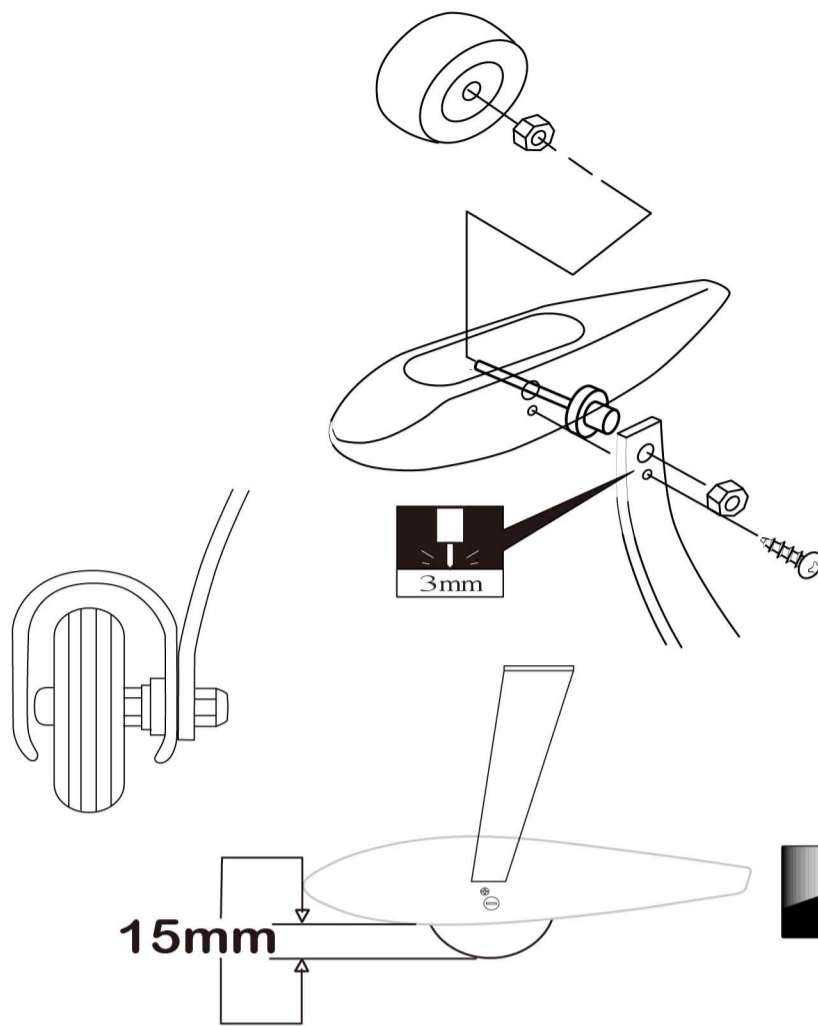

16 Adjust the travel of each control surface to the values in the diagrams. These values fit general capabilities. Readjust according to your need and flight level.

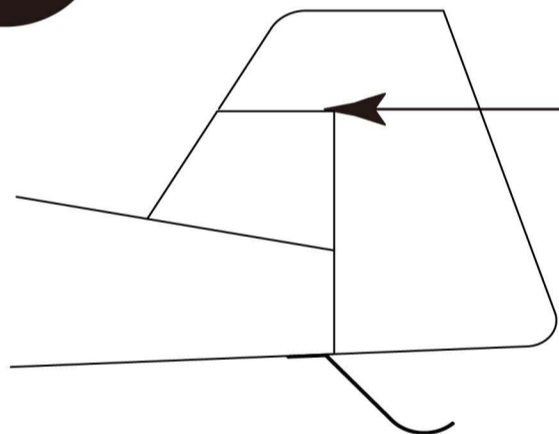

Position for right diagram.

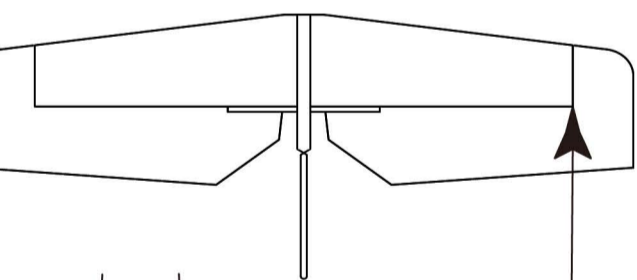

Position for right diagram.

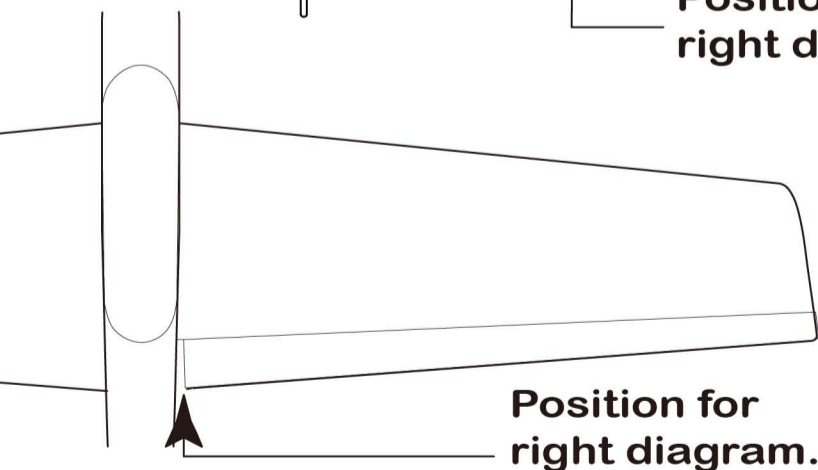

Position for right diagram.



Never fly before checking the CG,s required position.

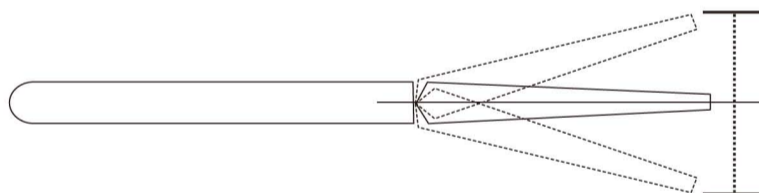

Rudder 45 degree low rate 35 degree

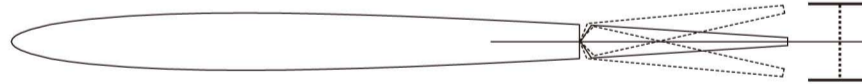

Elevator 45 degree low rate 25 degree



Aileron 35 degree low rate 20 degree



Pay close attention here!

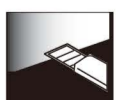

Cut off shaded portion.



Drill holes with the specified diameter.



Must be purchased separately!



Apply instant glue (C.A glue, super glue).



Assemble left and right sides the same way.



Cut off excess.



Apply epoxy glue.



Ensure smooth non-binding movement while assembling.

Always do observe the following in order to prevent accidents!

Before Flying

Before enjoying flying your airplane, sufficiently make sure the airfield is spacious. Always fly it outside rooms in safe areas with no debris or obstacles!

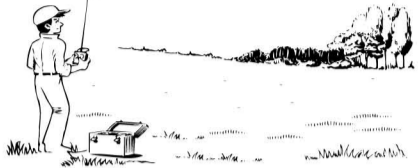

For radio equipment, refer to the manual included with the radio.

Check that the spinner and the propeller are securely fastened.

If the model begins to operate by itself, there is another transmitter on your frequency. Do not try to operate your model under such condition for it may go out of control.

Fully extend transmitter antenna.

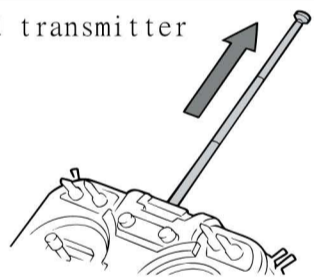

Switch on the transmitter.

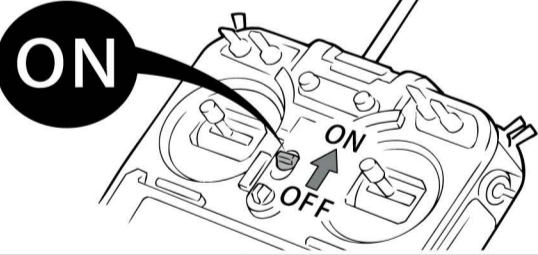

Switch on the receiver.

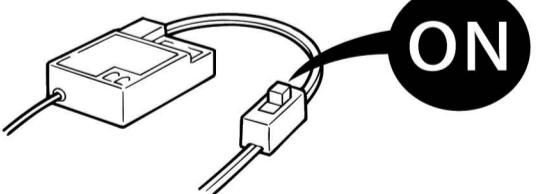

Check that the wings are properly and firmly affixed.

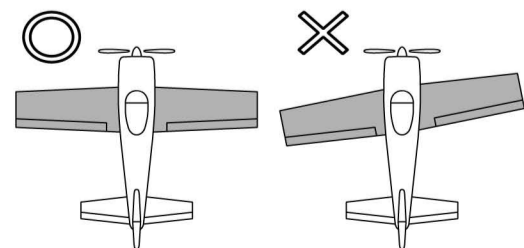

Flying

Do not fly your airplane when there is a strong wind or side wind.

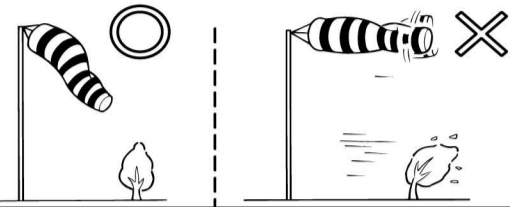

Fill in the fuel.

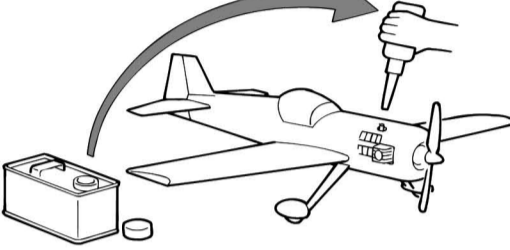

By moving the controls (transmitter), check that all rudders move the way you adjusted them.

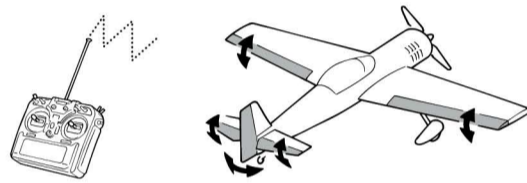

By moving the throttle control, check that the engine carburetor easily opens and closes.

For starting the engine, apply low throttle and hold the engine starter against the spinner.

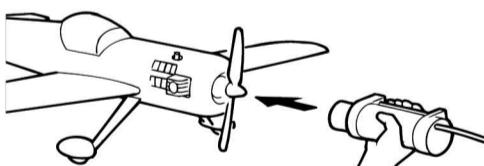

Adjust the needle.

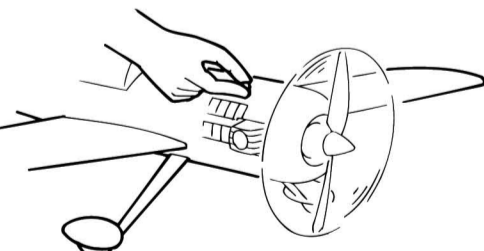

Hand-launch your airplane into the wind and make it take off.

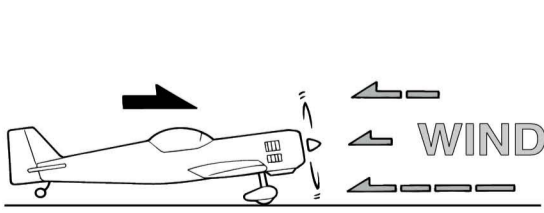

After Flying

Always land your airplane into the wind.

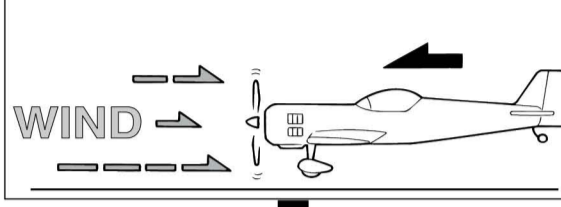

Bring your airplane to a halt by lowering the engine control trim.

After each flight, the engine is hot. Beware of getting burned.

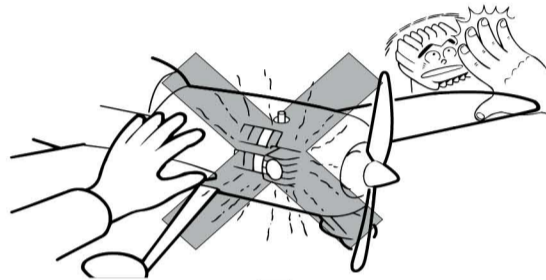

Switch off the receiver.

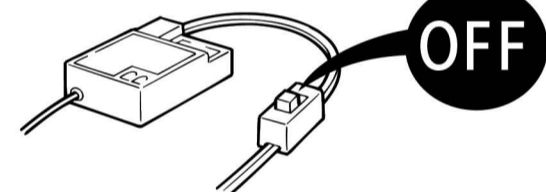

Switch off the transmitter.

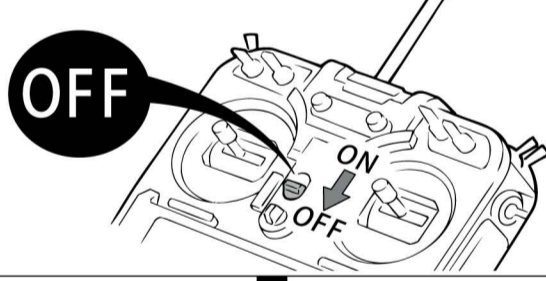

Draw the remaining fuel out of the tank and fill it back into the can.

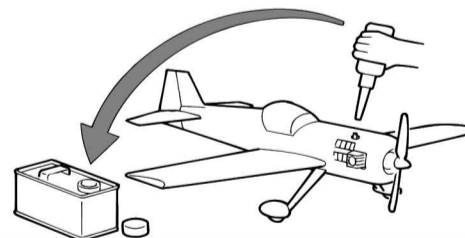

Wipe up any fuel deposits or dirt.

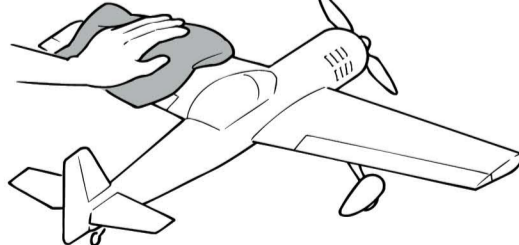

Only use XTECH COMPOSITE genuine part.

Cautions for Safety

Always regulate the engine from behind, but never from in front or from the sides, because a rotating propeller might badly injure you.

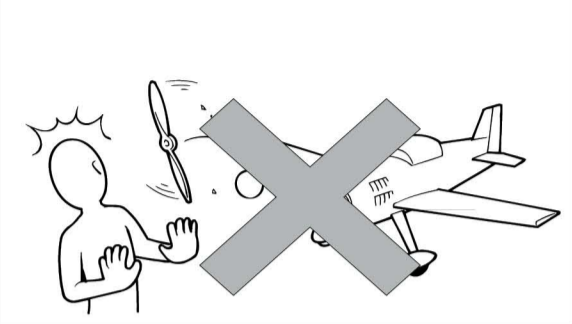

Do not allow watching people to get too close to a rotating propeller.



Immediately disuse defective propellers as well as deformed spinners.

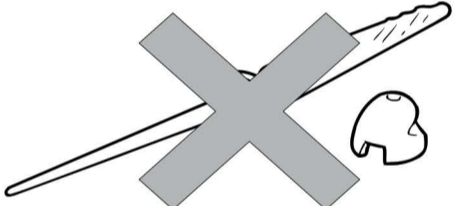

If the batteries of the radio system are flat, replace them with new ones.

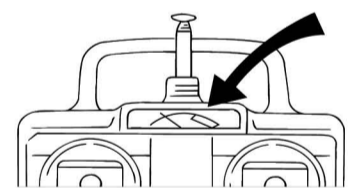

Do not fly your airplane above people standing around.

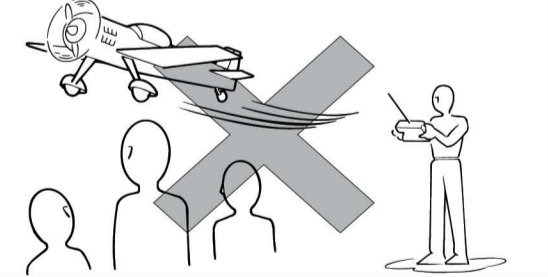

Never throw burning, gleaming or smouldering thing into fuel cans, even if these happen to be empty. This could result in serious injury.

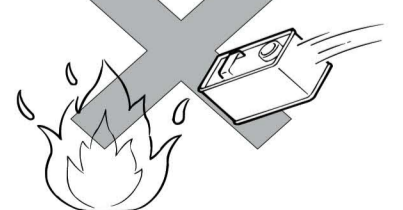

pro *AK*

Thanks again for choosing Engel Modellbau Aircraft. Enjoy your flying.

***X-TECH* QUALITY ENGINEER PRODUCT.**